

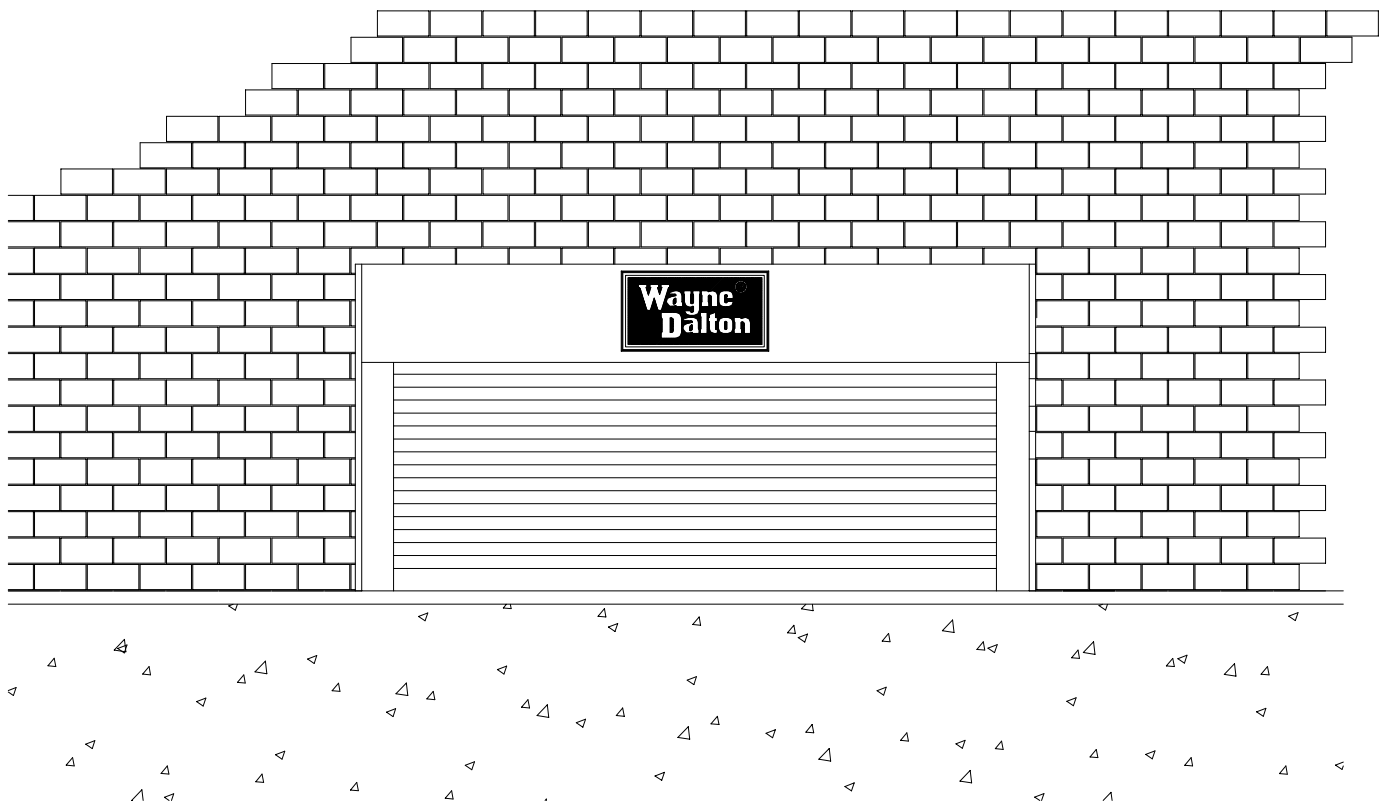

AtlerTM

Rolling Steel Fire Shutter

Installation Instructions
and
Operation and Maintenance Manual



IMPORTANT NOTICE !!

READ THE ENCLOSED INSTRUCTIONS CAREFULLY BEFORE ATTEMPTING TO REMOVE EXISTING SHUTTER OR INSTALLING THIS SHUTTER. PAY CLOSE ATTENTION TO ALL WARNING LABELS AND THE IMPORTANT SAFETY NOTICES ON THE FOLLOWING PAGE. THIS MANUAL MUST BE ATTACHED TO THE WALL IN CLOSE PROXIMITY OF THE SHUTTER.



IMPORTANT SAFETY NOTICES

[Read the enclosed instructions carefully before attempting installation. If in question about any of the procedures, do not perform the work. Instead, have a qualified door agency do the installation or repairs.]

1. Shutter installation must be in full compliance with all provisions of the regulations contained in **NFPA 802**.
2. Operate shutter **ONLY** when properly adjusted and free of obstructions.
3. Shutter is constantly under **EXTREME SPRING TENSION**. Repairs, adjustments, installation and removal, **ESPECIALLY of ADJUSTING WHEEL**, are dangerous so that such work should be performed **ONLY** by qualified door service people.
4. **DO NOT PERMIT** children to play with the shutter or the electrical controls. The child could get caught between the shutter and counter causing fatal injury.
5. If the shutter is now or later becomes electrically operated, any locking devices **MUST** be disengaged or electrically interlocked.
6. Stand clear of the path of the shutter while shutter is in motion. One could get caught between the shutter and countertop causing serious injury.
7. Should shutter become hard to operate or completely inoperative, it is recommended that a qualified door agency correct the problem to prevent any accident or injury.
8. Frequently check all bolted connections to make sure they are secure during the lifetime of the shutter to prevent injuries and accidents due to loose connections. Also check all cables for fraying and replace as required to prevent accidental release of fire drop mechanism that could result in serious injury.
9. To avoid injury, never place hands or fingers between the gears, governor mechanism components, or tension release mechanism components while the shutter is being operated or test dropped. Otherwise, broken bones or serious lacerations could occur by pinching the hands or fingers.
10. This manual is **NOT** intended to direct "take-down" procedures of existing shutters. Consult your local door authority if this is required before new shutters are to be installed.
11. Crew chiefs should consider using a 2-person crew for larger shutters.
12. Definition of key words used in this manual:

⚠ WARNING: Possible Bodily Harm and/or permanent shutter damage.

⚠ CAUTION: Possible permanent shutter damage

IMPORTANT! - Required step for safe and proper shutter operation.

NOTE: Necessary information or step in the installation of the shutter.

HINT: Suggested steps to simplify installation based on experience.

Wayne-Dalton Corp.

Limited One Year Warranty

Wayne-Dalton Corp., Dalton, Ohio 44618 warrants that every door and its hardware and fittings will be free of defects in workmanship and material. Should any defect in workmanship or material appear within ONE YEAR of installation, **Wayne-Dalton Corp.** shall, upon notification, correct such non-conformity at its option, by repairing or replacing any defective part or parts.

THIS WARRANTY GIVES YOU SPECIFIC RIGHTS WHICH VARY FROM STATE TO STATE.

This warranty does not include normal wear, damage beyond the manufacturer's control or replacement labor.

NO WARRANTIES EXPRESSED OR IMPLIED (INCLUDING, BUT NOT LIMITED TO, A WARRANTY OF MERCHANTABILITY OR FITNESS FOR PARTICULAR PURPOSE) SHALL EXTEND BEYOND THE APPLICABLE TIME PERIOD STATED IN BOLD FACE TYPE ABOVE.

Claims for the defective parts must be made to the Wayne-Dalton Corp. dealer from whom the purchase was made. Notification of defects in workmanship and material must be given to the dealer within the governing warranty period.

THE FOREGOING WARRANTY IS EXCLUSIVE AND IN LIEU OF ALL OTHER WARRANTIES. IN NO EVENT SHALL SELLER BE LIABLE FOR SPECIAL, INCIDENTAL OR CONSEQUENTIAL DAMAGES. HOWEVER, SOME STATES DO NOT ALLOW LIMITATIONS ON HOW LONG AN IMPLIED WARRANTY LASTS OR THE EXCLUSION OR LIMITATION OF INCIDENTAL OR CONSEQUENTIAL DAMAGES, SO THE ABOVE LIMITATION OR EXCLUSION MAY NOT APPLY TO YOU.

Atler™ Rolling Steel Fire Shutter Face Mounted (above lintel)

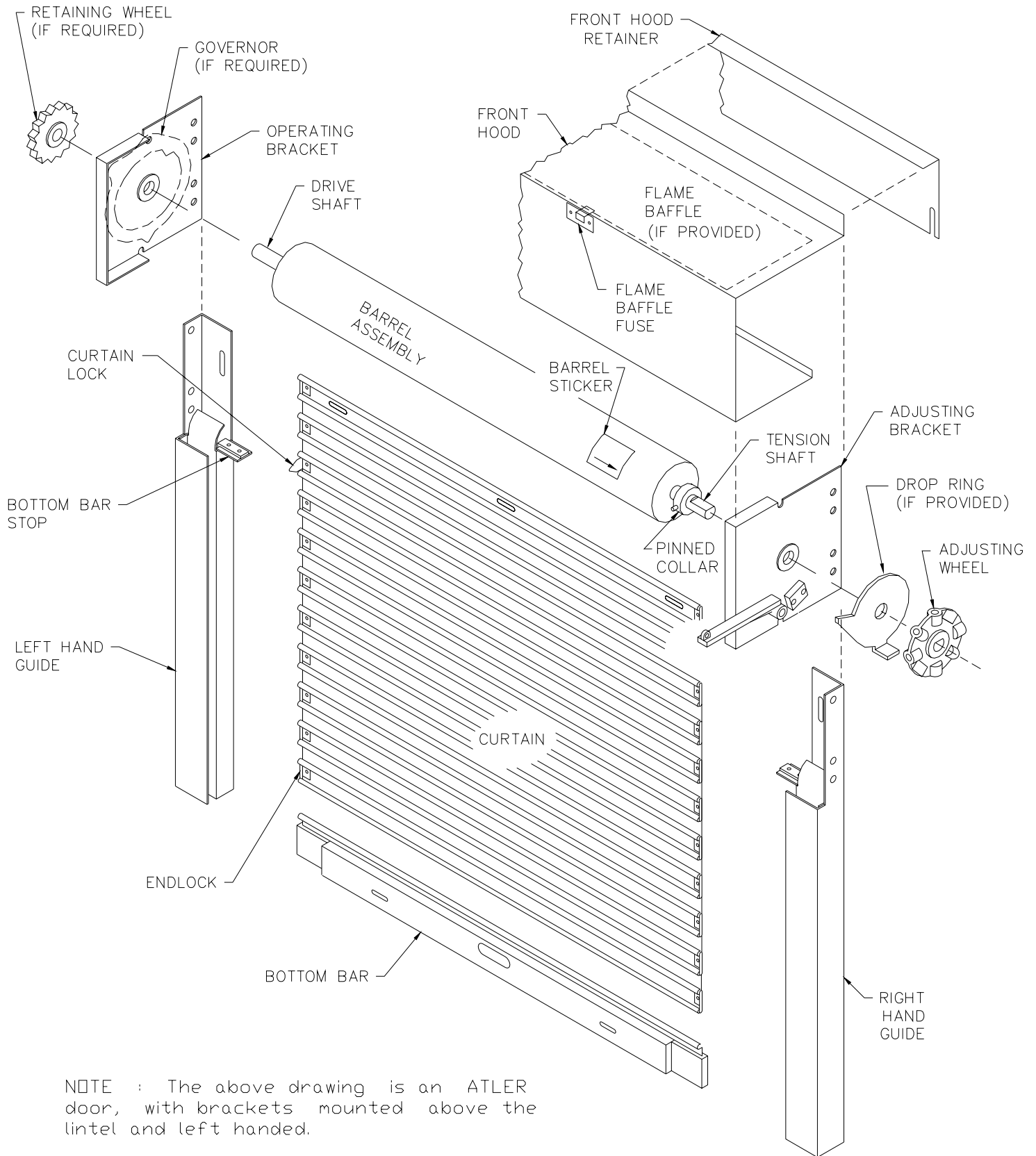

NOTE : The above drawing is an ATLER door, with brackets mounted above the lintel and left handed.

FIGURE #1

Atler™ Rolling Steel Fire Shutter Between Jambs (under lintel)

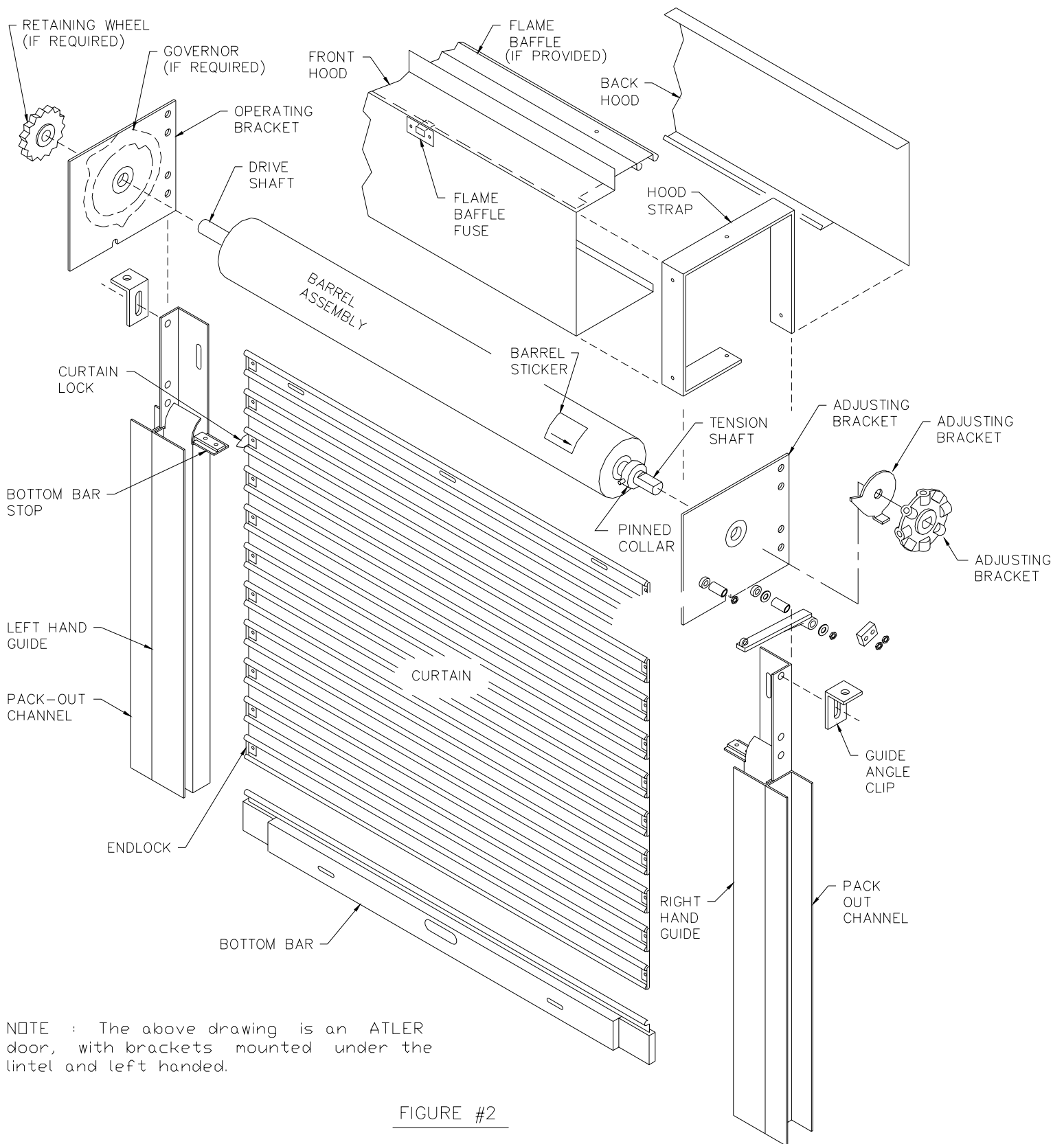

FIGURE #2

Table of Contents

	Page
About this Manual	i
Preparation	i
Shutter components and hardware	ii
Step 1 : Opening Checks	1
Step 2 : Guide mounting	2
Step 3 : Locating Hood Strap & Flame Baffle	6
Step 4 : Attach Curtain to Barrel Assembly	7
Step 5 : Governor Mechanism and Operator Bracket Assembly	9
Step 6 : Attaching Brackets to Guides	12
Step 7 : Installing Inner Guide Assembly	13
Step 8 : Applying Tension	14
Step 9 : Testing Shutter Balance	17
Step 10 : Fusing and Cabling the Shutter	17
Step 11 : Test Dropping Shutter	18
Step 12 : Shutter Resetting Procedure	21
Step 13 : Hoods, Hood Straps & Housings	19
Optional Components	Appendix A
Service Record	Appendix B
Trouble Shooting	Appendix C
Additional Fuse Cabling	Appendix D
Rolling Fire Door Test Drop Release Form	Appendix E

INTRODUCTION

This manual's main function is to assist the installer in correctly mounting shutters with due regard for safety, operation, and sound construction practices. NFPA 80 and local fire and building codes take precedence with regard to any discrepancies among them.

All Wayne-Dalton Adler[®] Rolling Fire Shutters follow the general guidelines set forth herein. Additional installation information for each shutter shipped is found in the packing slip and supplementary drawings. There are also bolt and small parts bags sealed separately with accessory lists describing what part goes where.

PREPARATION

Read the installation instructions to become familiar with the names of the various components and their relation to each other. It is a necessity for the installer to determine the following:

- The type of mounting (above lintel or under lintel).
- Method of operation (hoist, crank, motor, or push-up).
- The hand of operation determined from the coil side (right or left).
- Type of jamb on which the shutter guides mount and the fasteners required.
- The dimensions for the opening width, opening height, head room, and side room.

MATERIAL

Inspect your shutter prior to leaving for job site for possible damage or shortage of parts. Report any claims or shortages to your door supplier immediately.

CLEARANCES

The installation drawings supplied in the hardware bag contain information on bracket size and head and side room for each shutter. Be sure that the dimensions are correct for the opening you are working on. Take special note of the "C" dimension (Figure 4,p2). **THIS DIMENSION MUST BE HELD IN ORDER TO PREVENT INTERFERENCE WITH THE PROPER OPERATION OF THE SHUTTER WHILE BEING CLOSED.** Be sure the required clearances are available prior to installation.

TOOLS

The tools recommended for proper installation of each shutter will vary, but commonly used tools are:

- Electric drill with 3/8" or 1/2" chuck.
- Masonry drill or impact hammer and bits.
- Chain hoist and sling for raising barrel and curtain assembly.
- Ladders and scaffolding.
- Wrenches, screwdrivers, hammer, level, drills, center punch, tape measure, chalk line, vise grips or C-clamps, water-level hose.
- Two hardened steel bars, 1/2" diameter and approximately 36" long.

Section 1 - Supplied Parts List

Major Components and Assemblies

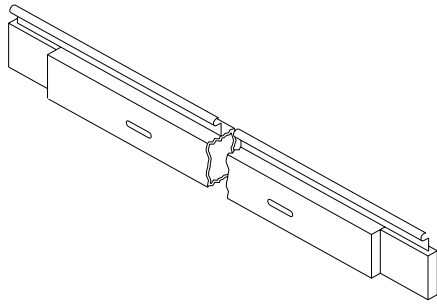

BOTTOM BAR ASSEMBLY

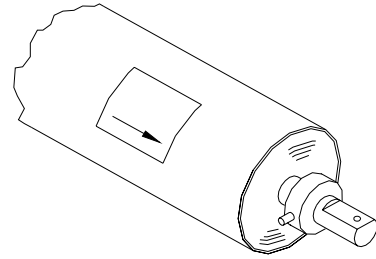

BARREL ASSEMBLY

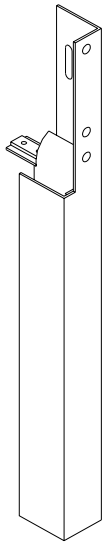

ABOVE LINTEL
GUIDE ASSEMBLY

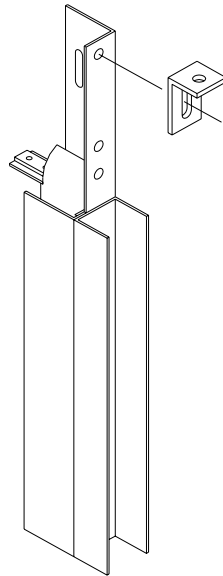

UNDER LINTEL
GUIDE ASSEMBLY

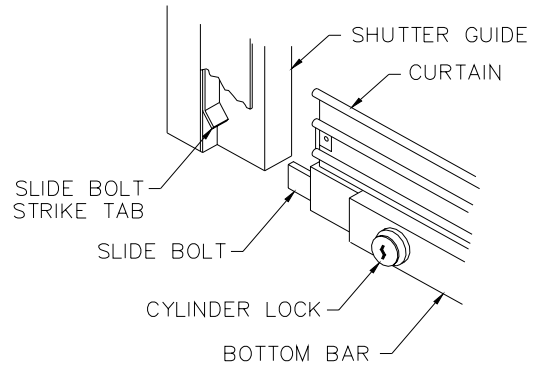

CYLINDER LOCK OR
SLIDE BOLT ASSEMBLY

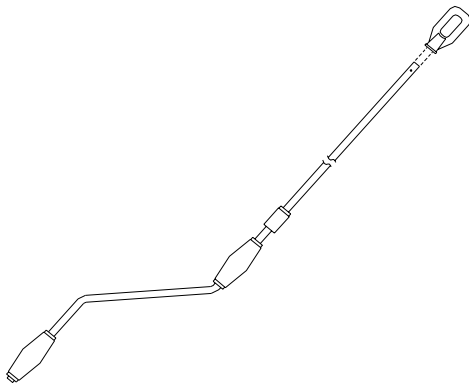



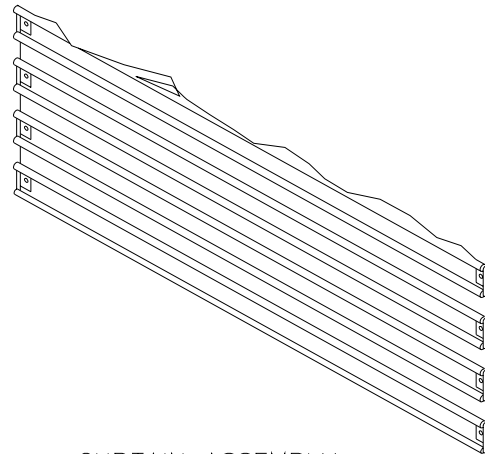

AWNING CRANK WINDING SHAFT



CURTAIN ASSEMBLY

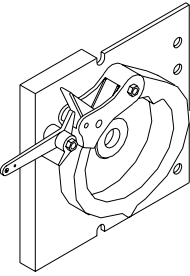
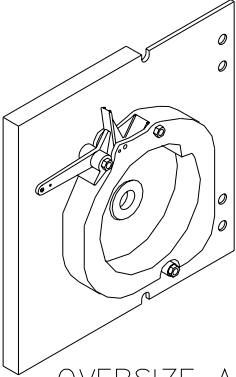
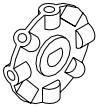

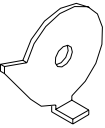
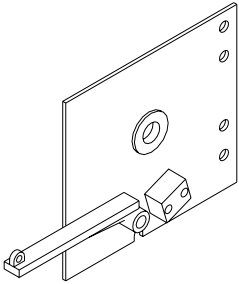
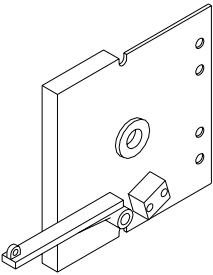
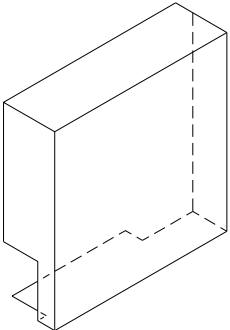
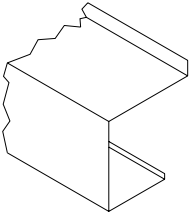
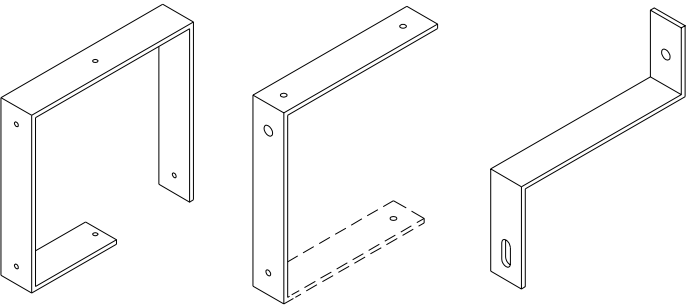
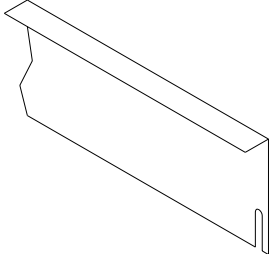

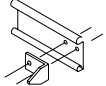
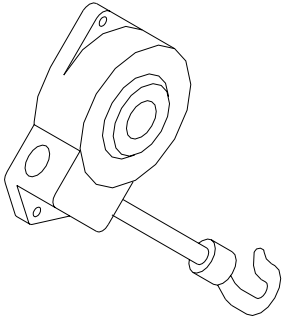
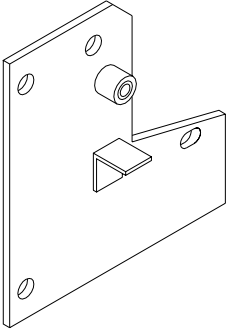
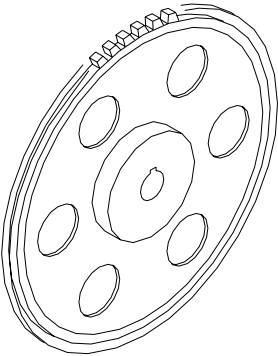
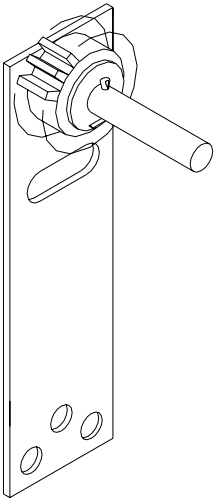

Section 2 - Supplied Parts List

Bracket Assemblies and Components

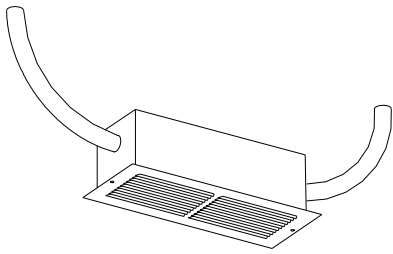
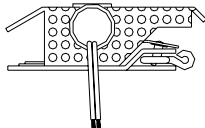
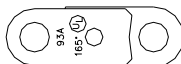
 <p>ABOVE LINTEL OP. BRACKET ASS'Y</p>	 <p>OVERSIZE ABOVE LINTEL OP. BRACKET ASS'Y</p>	 <p>ADJUSTING WHEEL</p>	 <p>RETAINING WHEEL</p>
		 <p>DROP RING (IF PROVIDED)</p>	
 <p>UNDER LINTEL AW BRACKET ASSEMBLY</p>	 <p>ABOVE LINTEL AW BRACKET ASSEMBLY</p>	 <p>BRACKET HOUSING</p>	 <p>FRONT HOOD</p>
 <p>HOOD STRAPS</p>			 <p>FRONT HOOD RETAINER</p>
		 <p>GROOVE MOUTH</p>	 <p>CURTAIN LOCK</p>
 <p>AWNING CRANK</p>	 <p>OP. DROP OUT PLATE ASSEMBLY</p>	 <p>MAIN GEAR</p>	 <p>PIVOT ARM W/GEAR</p>

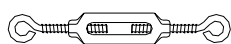
Section 3 - Supplied Parts List

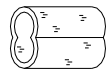
Miscellaneous Components and Hardware

 FUSE LINK HOUSING P.N. 004-0770-20	 HOLDER RELEASE	 FUSIBLE LINK		
		 AW PIN P.N. 004-0602-04	 HITCH PIN P.N. 807-0696-04	
 TURNBUCKLE P.N. 004-0770-20	 "S" HOOK P.N. 812-0023-05	 COTTER PIN P.N. 807-0171-04	 NICO PRESS FITTING P.N. 812-0036-04	 FUSE CABLE P.N. 677-0203-24

Also included is a bag of hardware with a packing slip to show where each piece is used. Below is an example (yours may vary in sizes and quantities) including a ruler for your convenience :

No/

Door	Part Number	Description	Where Used
2	004-0602-04	Pin - Adjusting Wheel (Bullet)	AW to Bracket
2	807-0696-04	Pin - #13 Hitch (Hair Pin)	AW to Bracket
2	807-0171-04	Cotter Pin - 3/16" x 1-1/2"	AW & Retaining Wheel
6	801-0350-05	1/2"-13x1-1/2" HH Cap Screw	Brackets to Guides
6	802-0004-05	1/2"-13 Hex Nut	Brackets to Guides
18	805-0100-04	3/8" x 3-3/4" Stud Anchors	Guides to Wall
5	801-1070-05	1/4"-20 x 1-1/2" RHMS	Hood to Wall
5	805-0129-04	1/4" x 1" Expansion Shield	Hood to Wall
5	804-0002-05	1/4" Flat Washer	Hood to Wall
10	803-1807-05	1/4"x1/2" Self-Tapping Screw	Hood to Brackets/Strap
10	801-0274-05	5/16"-18 x 1" HHCS	Top Slat to Ring
10	802-0031-05	5/16"-18 Square Nut	Top Slat to Ring
10	804-0025-05	5/16" Flat Washer	Top Slat to Ring

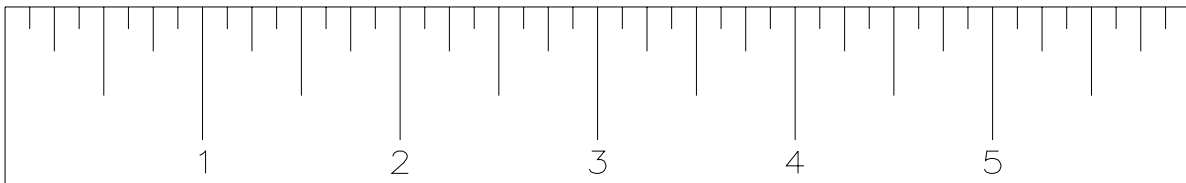

Step 1: Opening Checks

Refer to Figure 3. Check the opening width "A" and the opening height "B" or "F" and compare with the installation drawing to be sure the opening is the proper size for the shutter. Any variations in the actual opening width, height, or plumb condition of the jambs, are to be disregarded when installing the guides. Verify the clearances available meet or exceed those given on the installation drawing.

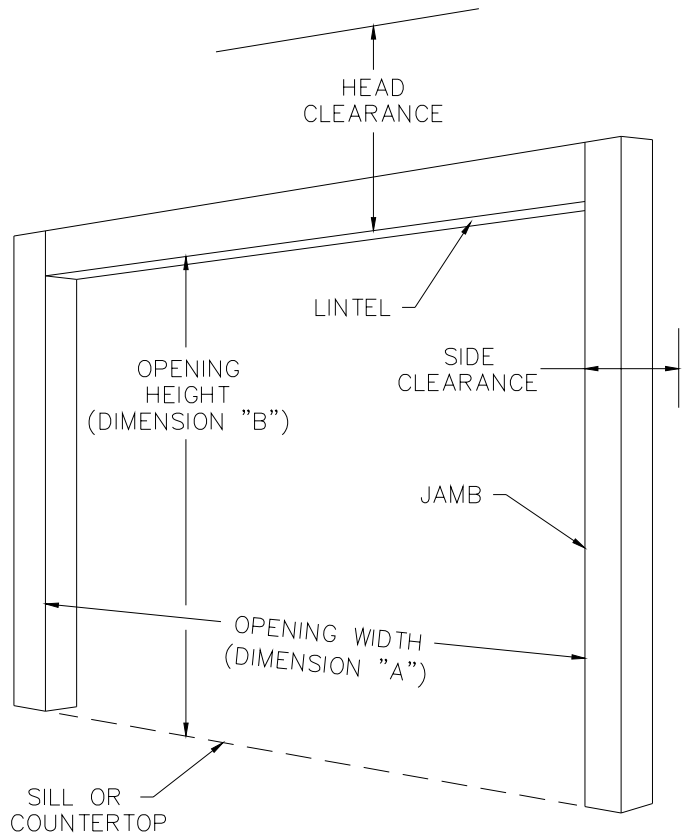
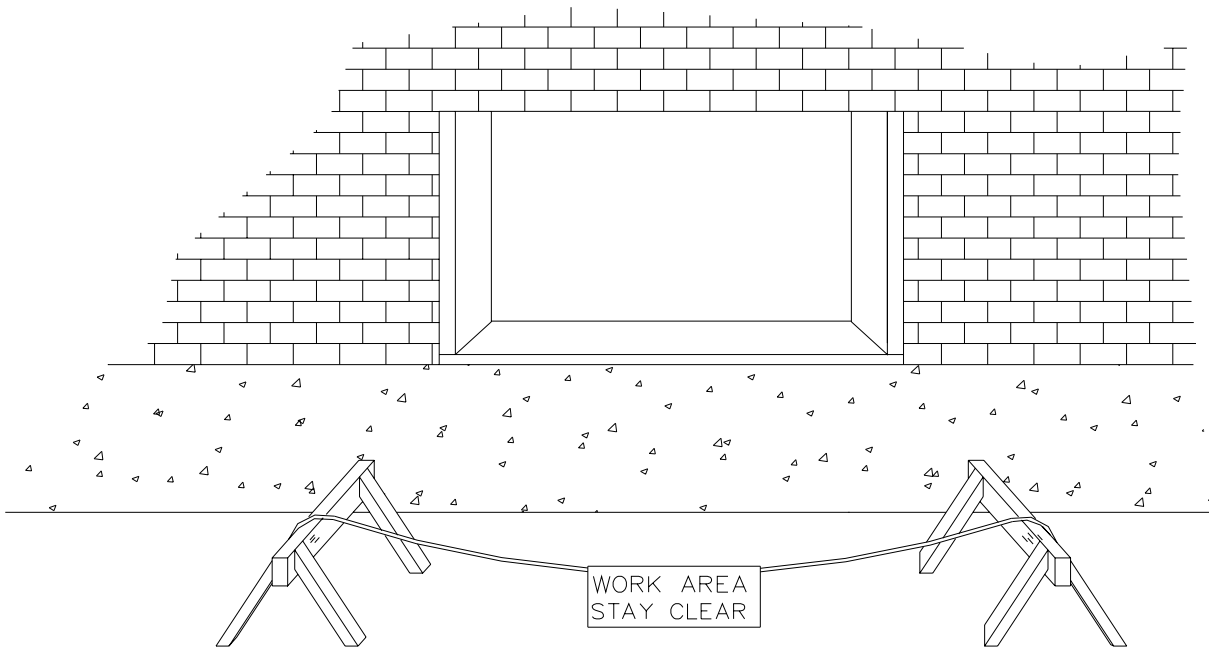

FIGURE #3



Rope off the opening prior to beginning work!

Step 2 : Guide Mounting

Face Mounted (Brackets Above Lintel) Shutters (skip to "Between Jambs...." section on for brackets mounted below lintel)

The inner and outer guides are factory assembled, but must be disassembled in order to be installed (See Figure #5A). Take care not to lose any flathead screws; these are difficult to replace. Group the parts of each guide together since they are handed and not interchangeable.

Refer to Figure #4. To determine the location of the "bolt line" (BL) for the guide mounting bolts on the wall, first locate and mark the center of the opening. Obtain the "C" dimension from the installation drawing and subtract 1" for masonry jambs or 3 1/2" for steel jambs to determine the bolt line (BL).

"C" Dimension (from Dwg) _____
 - 1" or -3 1/2"
 Bolt line (BL) _____

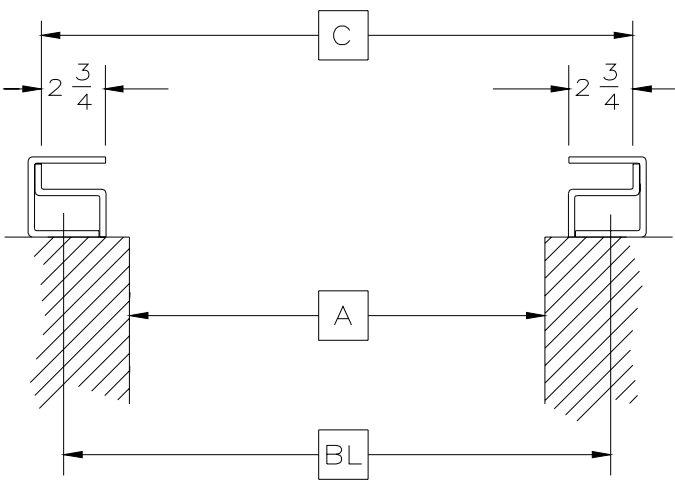

FACE MOUNTED GUIDES

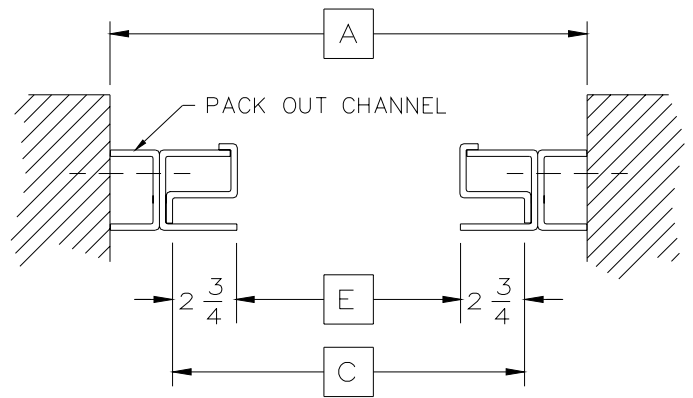

BETWEEN JAMBS MOUNTED GUIDES

FIGURE #4

Divide **BL** in half (**BL/2**) and measure this distance either side of the opening center mark to obtain the bolt line on each jamb. Drop a plumb line down and make a second mark on the wall at the bottom of each jamb. Using a chalk line, snap a vertical line the length of the "**F**" dimension.

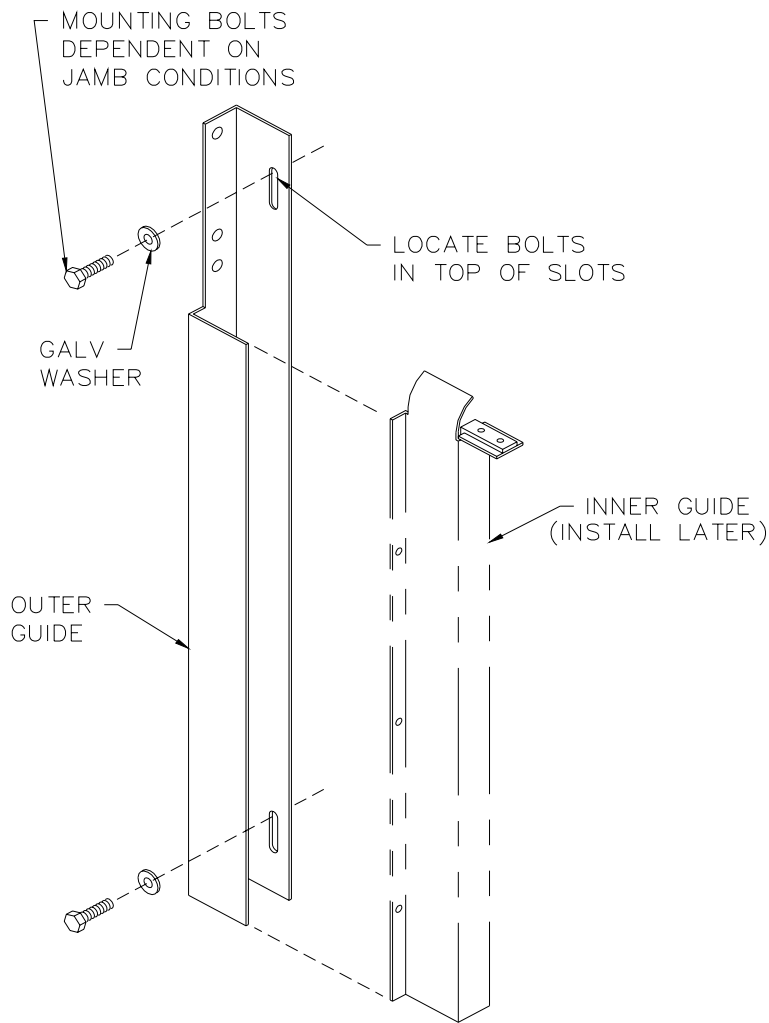

FIGURE #5A

Next, temporarily clamp or hold the channel shaped "outer guides" to jamb, carefully aligning center of slots along the chalk "bolt line".

⚠ WARNING - WELDING THE GUIDES TO THE JAMBS IS NOT ALLOWED DUE TO THE VERTICAL EXPANSION REQUIRED FOR THE SHUTTER TO FUNCTION PROPERLY.

After determining guides are plumb, level and properly spaced, scribe the location of the guide mounting slots on each jamb.

NOTE: ATLER™ FIRE SHUTTERS ARE DESIGNED TO EXPAND UPWARD. FOR THIS REASON, MOUNTING BOLTS MUST BE LOCATED AT THE TOP OF THE SLOTS.

IMPORTANT! THE GALVANIZED WASHERS MUST BE INSTALLED TO ENSURE PROPER GUIDE EXPANSION IN EVENT OF FIRE.

Remove the guides and drill the appropriate size mounting holes for the fasteners provided (listed as "Guides-to-Wall" on hardware shipping list). Locate them in the **TOP** of the slot. Repeat this process for the remaining holes. Install top and bottom bolts in both guides with hardware provided. Check the **"C"** dimension and compare with the installation drawing.

IMPORTANT! THE GUIDE TO GUIDE DISTANCE, OR "C" DIMENSION ON THE INSTALLATION DRAWING MUST BE HELD. (See Figure #4.)

Using a string and a level, ensure that the guides are parallel to each other, shimming if necessary to achieve vertical and horizontal leveling. Now install the remaining bolts.

IMPORTANT! THE FASTENERS SUPPLIED MEET ALL NFPA 80 REQUIREMENTS SET FORTH. USE OF ANY OTHER TYPE FASTENER MUST BE ON THE APPROVED SUBSTITUTION LIST IN NFPA 80 AND CANNOT BE OF A LESSER DIAMETER.

NOTE: THE INNER GUIDE CANNOT BE INSTALLED AT THIS TIME, SINCE THE BOTTOM BAR ASSEMBLY WILL NOT PASS THROUGH THE TOP OPENING OF THE GUIDE ASSEMBLY. THIS PROCEDURE WILL BE COVERED IN STEP #7, "INSTALLING INNER GUIDE ASSEMBLY". HOWEVER, IT IS RECOMMENDED TO TEMPORARILY CLAMP THE INNER GUIDE IN PLACE TO CHECK THE "C" DIMENSION AT THIS TIME.

Between Jambs (Brackets Under Lintel) Shutters: (Refer to "Face Mounted..." on page 2 for brackets mounted above lintel)

The inner and outer guides are factory assembled, but must be disassembled in order to be installed (See Figure #5B). Note that "pack-out" channels are also required, and are slotted to match the guides. Also, with mechanically operated shutters, the pack-out channel on the operator side may be larger to gain additional side clearance. Take care not to lose any flathead screws; these are difficult to replace. Group the parts of each guide together since they are handed and not interchangeable. Next, determine the location of the "bolt line" (BL) for the guide mounting bolts on the wall. (Follow this procedure for either masonry or steel jambs-see Figure #4.)

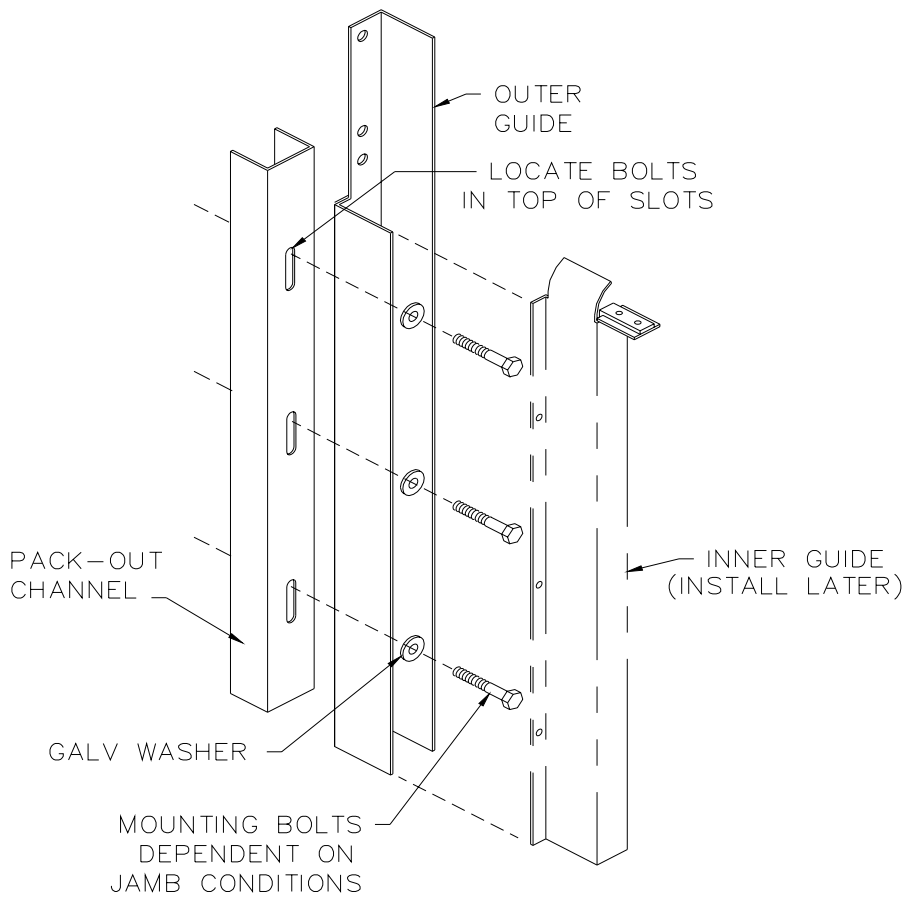

FIGURE #5B

Choose one "outer guide" channel (**not pack-out channel**) to be used as a template. Temporarily clamp the channel in the proper jamb (i.e., left channel in left jamb) at the exact location in the opening the shutter is to be mounted. After determining that the guide outer channel is plumb, level and properly spaced into the opening, carefully scribe the location of each guide mounting slot on the jamb. Repeat this procedure for the opposite side making sure that the channel is located at exactly the same distance into the opening.

⚠ WARNING: WELDING THE GUIDES TO THE JAMBS IS NOT ALLOWED DUE TO THE VERTICAL EXPANSION REQUIRED FOR THE SHUTTER TO FUNCTION PROPERLY.

Remove the outer guide channels and drill the appropriate size mounting holes for the fasteners provided (listed as "Guides-to-Wall" on hardware shipping list). Locate them in the TOP of the slot. Repeat this process for the remaining holes. It is a good practice to align a chalk line with the center of the top and bottom slot, and snap a line to better locate the drill.

NOTE: ATLER™ FIRE SHUTTERS ARE DESIGNED TO EXPAND UPWARD. FOR THIS REASON, MOUNTING BOLTS MUST BE LOCATED AT THE TOP OF THE SLOTS.

Install both the pack-out channel and outer guide angle together on each jamb starting with the top and bottom bolts using the hardware provided. Using a string and a level, ensure that the guides are parallel to each other, shimming if necessary to achieve vertical and horizontal leveling. Now install the remaining bolts.

IMPORTANT! THE IMPROPER "C" DIMENSION MAY PREVENT PROPER OPERATION OF THE SHUTTER.

IMPORTANT! THE FASTENERS SUPPLIED MEET ALL NFPA 80 REQUIREMENTS SET FORTH. USE OF ANY OTHER TYPE FASTENER MUST BE ON THE APPROVED SUBSTITUTION LIST IN NFPA 80 AND CANNOT BE OF A LESSER DIAMETER.

IMPORTANT! THE GALVANIZED WASHERS MUST BE INSTALLED TO ENSURE PROPER GUIDE EXPANSION IN EVENT OF FIRE.

NOTE: THE INNER GUIDE CANNOT BE INSTALLED AT THIS TIME, SINCE THE BOTTOM BAR ASSEMBLY WILL NOT PASS THROUGH THE TOP OPENING OF THE GUIDE ASSEMBLY. THIS PROCEDURE WILL BE COVERED IN STEP#7, "INSTALLING INNER GUIDE ASSEMBLY". HOWEVER, IT IS RECOMMENDED TO TEMPORARILY CLAMP THE INNER GUIDE IN PLACE TO CHECK THE "C" DIMENSION AT THIS TIME.

Step 3: LOCATE HOOD STRAPS & FLAME BAFFLE

This Section Applies to Between Jambs (Brackets Under Lintel) Shutters Only:
(Skip to Step #4 if Shutter is "face mounted" i.e., brackets above lintel.)

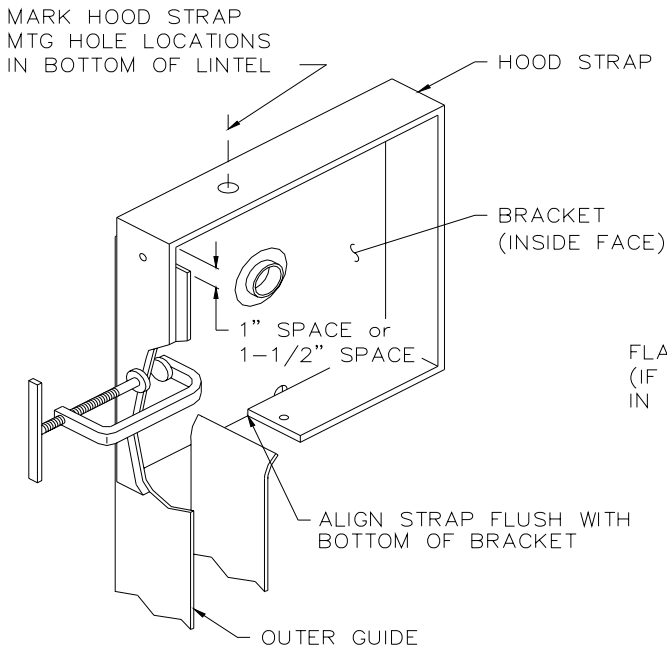

FIGURE #6A

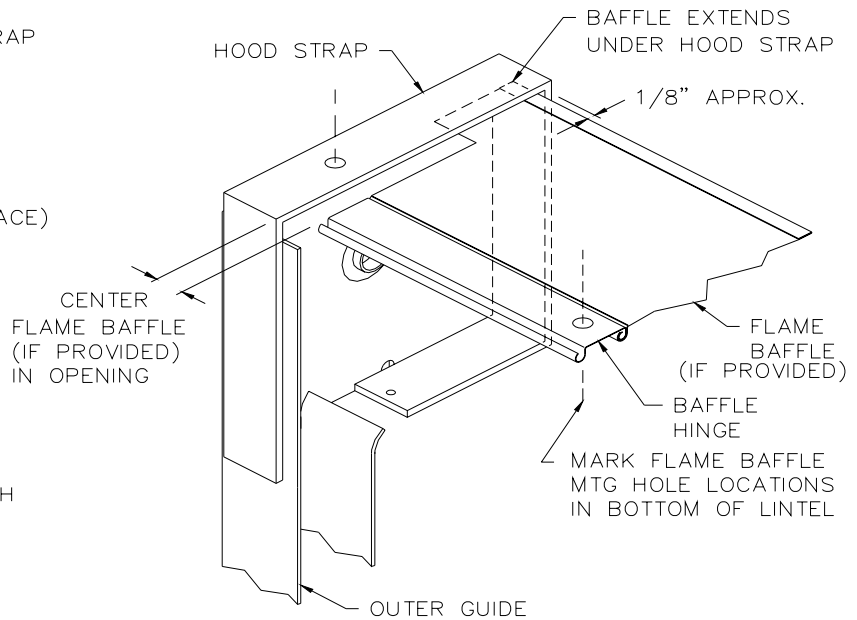

FIGURE #6B

If the brackets are "under lintel", the mounting holes for the hood straps and flame baffle must be drilled prior to erecting the barrel and curtain assembly. Temporarily attach the brackets to the guides. (Refer to Figure 6A).

Position each hood strap tightly against and flush with the front and bottom of each bracket as shown in Figure #6A. The back of the hood strap should loop over the top and back side of the guide.

NOTE: A 1" TO 1½" SPACE EXISTS BETWEEN THE TOP OF THE BRACKET AND THE BOTTOM OF THE LINTEL, SINCE ATLER™ SHUTTERS ARE DESIGNED TO EXPAND UPWARD (SEE INSTALLATION DRAWING FOR EXACT DIMENSION).

Clamp the hood straps to the guides temporarily and use the straps as a template to scribe the location of the mounting holes under the lintel. Position the flame baffle (if provided) under the lintel as shown in Figure #6B with the hinge to the back and centered between the hood straps. A clearance of 1/8" should be held from edge of the baffle to the inside face of the hood straps (see Figure #6B). Check to see that the baffle swings down freely and also will catch on the flame baffle fuse (attached to the front hood) which supports it. Mark the position under the lintel for three equidistant holes through the hinge. Remove the flame baffle, hood straps, and brackets and drill the marked holes in the lintel.

Step 4: ATTACHING THE CURTAIN TO THE BARREL ASSEMBLY

Lay out the curtain and barrel assembly in front of the opening. Note the green sticker located on the right hand end of the barrel. This sticker will indicate the right hand end, the direction the curtain uncoils to close the shutter, and the spring turns required to balance the shutter.

Orient the barrel with its right hand end on the right side of the opening. Center the top slat of the curtain with the barrel assembly and connect it to the barrel rings as shown in Figure 7. If rings are not provided, attach the top slat to bare pipe at weld nut locations. Tighten the bolts such that the head of the bolt will not interfere with the curtain as it coils. Do not distort the top slat by over tightening the bolts.

IMPORTANT! LONGER BOLTS THAN PROVIDED MUST NOT BE USED, AS THEY MAY INTERFERE WITH THE INTERNAL PARTS OF THE BARREL.

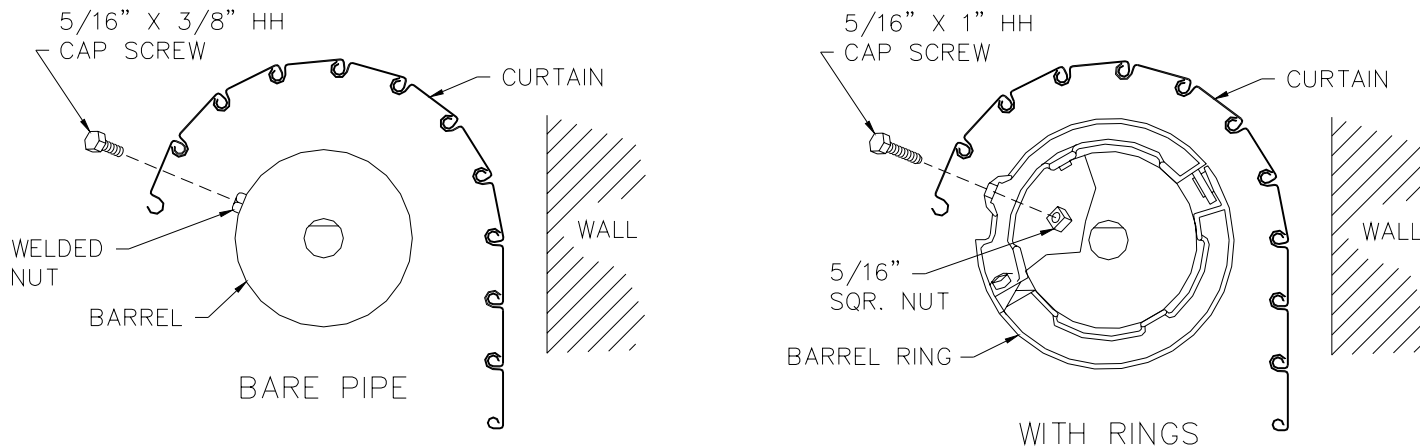

FIGURE #7

Slide the brackets onto the barrel shaft extensions and place the brackets on wood blocks as shown in Figure 8. If a drop ring was provided with your door (used on small openings), slide it onto the shaft next to the bracket (see Figure 9). Install the adjusting wheel onto the barrel shaft extension (with the flat) as shown in Figure 9 and lock it in place with a cotter pin. Apply tension to roll the curtain onto the pipe

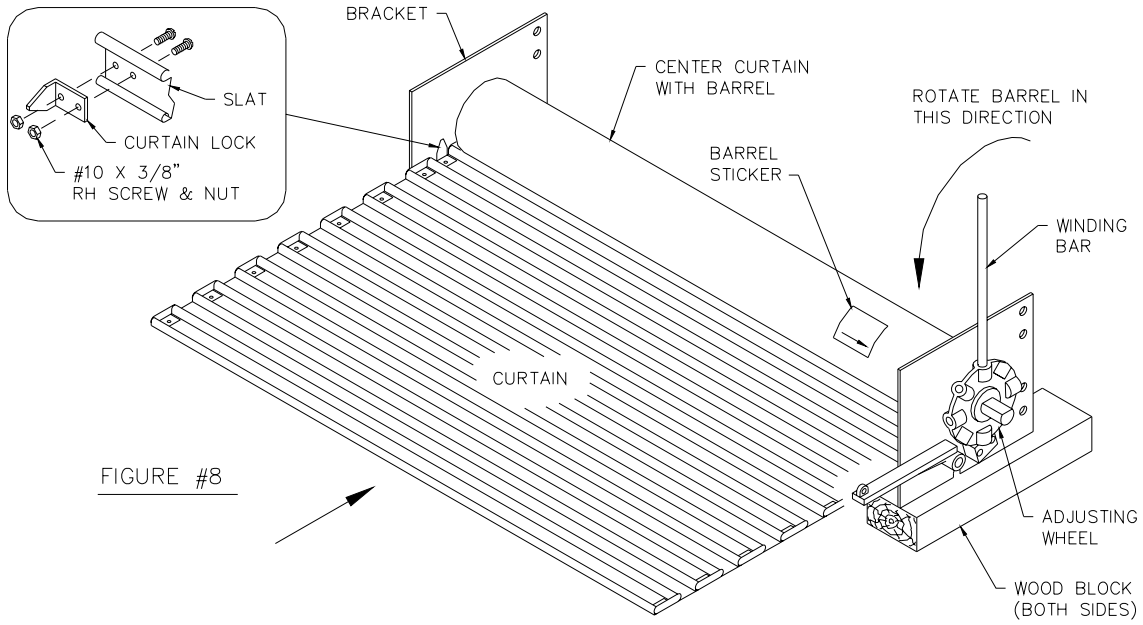

FIGURE #8

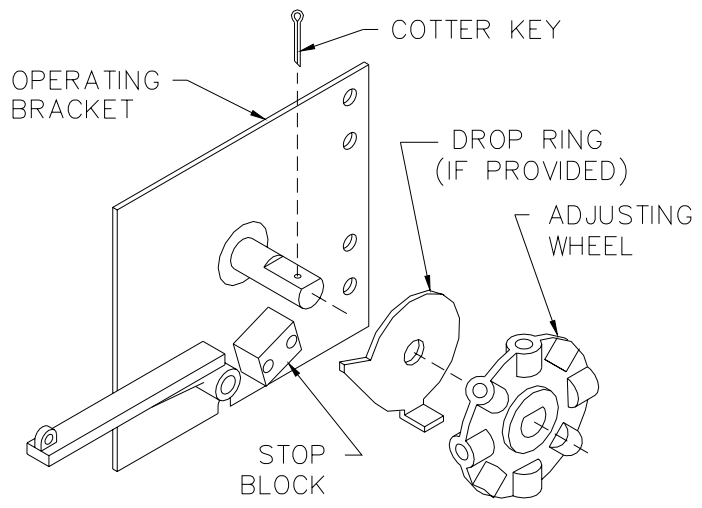

FIGURE #9

NOTE: TAKE PRECAUTIONS TO PREVENT THE CURTAIN FROM BEING DAMAGED WHEN SLIDING ON THE FLOOR.

Tie a rope around the coil to keep the curtain from uncoiling.

NOTE: GENERALLY THE SPRINGS ARE CLOSER TO THE ADJUSTER SIDE MAKING THE COIL ASSEMBLY HEAVIER AT THAT END.

Step 5: GOVERNOR MECHANISM AND OPERATOR BRACKET ASSEMBLY

Proceed with the operating bracket assembly while the shutter is still resting on the wooden blocks. On larger shutters, a governor mechanism is required to control the shutter's descent during a fire condition. If a governor has been provided, slide the retaining wheel onto the drive shaft as shown in Figure 10. Center it with the governor and secure using the key and cotter pin provided with the letter marking on the outside and center it with the governor ring.

NOTE: THERE IS AN "L" MARK FOR LEFT HAND OPERATED DOORS AND AN "R" MARK FOR RIGHT HAND OPERATED DOORS WHICH IS TO FACE OUT.

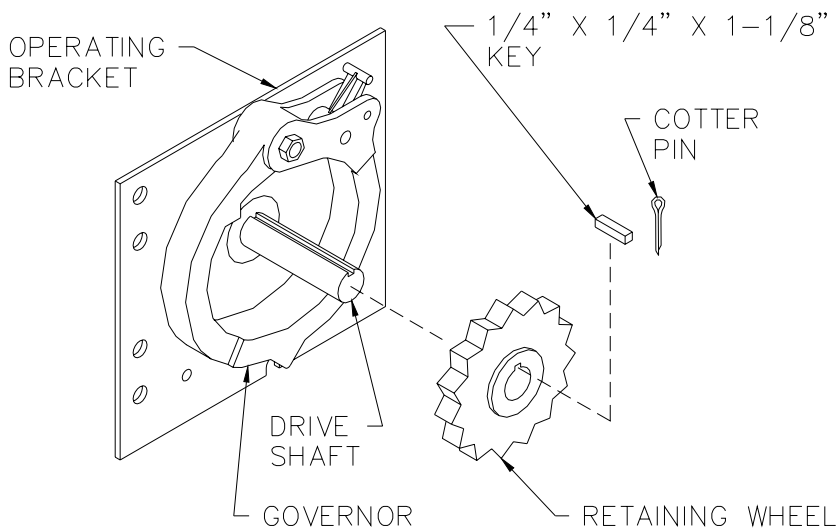

FIGURE #10

NOTE: THESE PARTS ARE MATCHED AT THE FACTORY AND ARE IDENTIFIED AS PAIRS. IF THERE IS MORE THAN ONE SHUTTER ON THE ORDER, VERIFY THE LETTER MARKING ON THE RETAINING WHEEL MATCHES THAT ON THE GOVERNOR RING.

CAUTION - ALL PARTS (EXCEPT KEYS) ARE DESIGNED FOR A SLIP FIT. FORCING PARTS TOGETHER MAY RESULT IN DAMAGE LEADING TO MALFUNCTION.

Manually Operated Shutters (Push-up): Skip to Step #6.

Mechanically Operated Shutters

Awning Crank Operated

Install the awning crank as shown in Figure #11. If a governor is not provided, the gear spacer is not required, and a third sleeve spacer is used to balance the gear box support plate.

Motor Operated: Install the power unit support and drop-out mechanism as shown in Figure #12.

⚠ WARNING - KEEP HANDS, ARMS AND CLOTHING FREE OF MESHING GEARS. MECHANISM AND GEARS MOVE FREELY AND QUICKLY SO THAT THEY COULD CAUSE SERIOUS INJURY.

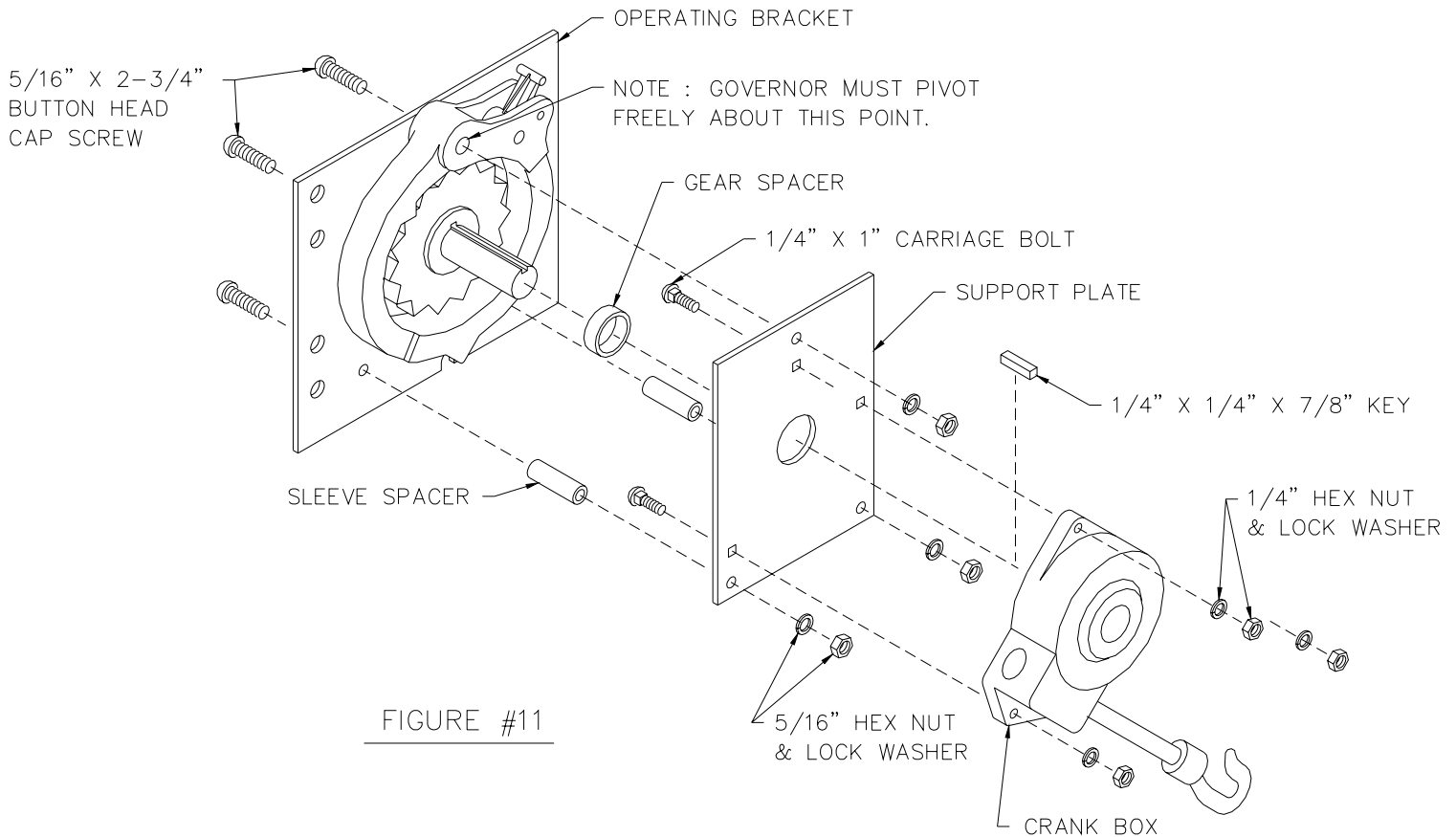

Motor Operated Atler™ - Drop Out Mechanism (RH Shown, LH Opposite)

FIGURE #12

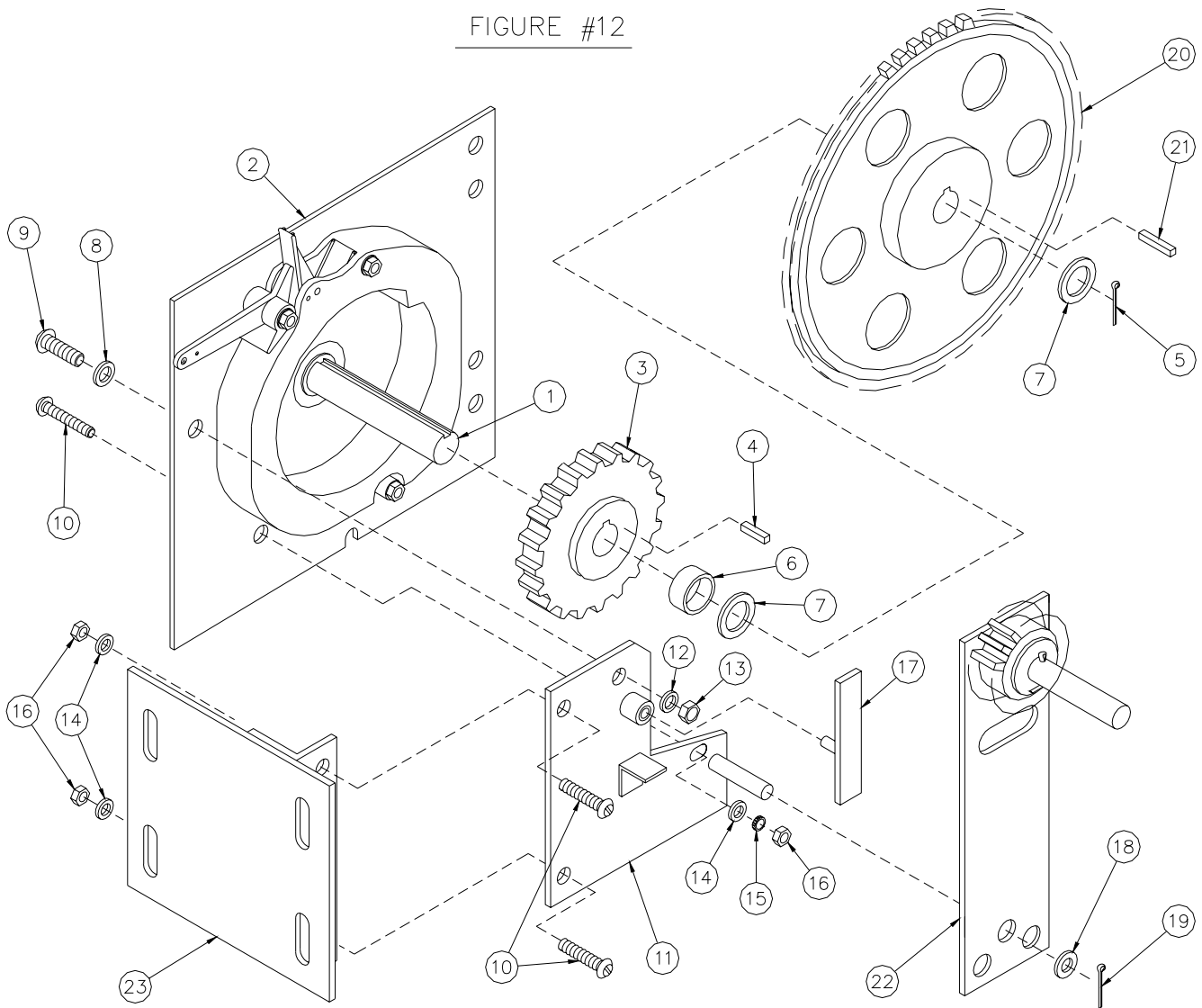

ITEM	DESCRIPTION	ITEM	DESCRIPTION
1	BARREL DRIVE SHAFT	12	WASHER-SHKPRF. 1/2" I.D.
2	BRACKET ASSEMBLY 14"	13	HEX NUT 1/2"-13
3	RETAINING WHEEL	14	WASHER-FLAT 7/16" I.D.
4	KEY 1/4" SQ. X 1-1/8" LG.	15	WASHER-SHKPRF. 3/8" I.D.
5	COTTER PIN 3/16" X 1-1/2"	16	HEX NUT 3/8"-16
6	GEAR SPACER	17	SUPPORT ARM
7	WASHER-FLAT 1-1/64" I.D.	18	WASHER-FLAT 33/64" I.D.
8	WASHER-FLAT 9/16" I.D.	19	COTTER PIN 1/8" X 1-1/2"
9	BTN. SOC. HD. CAP SCR. 1/2"-13	20	MAIN GEAR
10	BTN. SOC. HD. CAP SCR. 3/8"-16	21	KEY 1/4" SQ. X 1-1/2" LG.
11	HOIST MOUNTING PLATE	22	PIVOT ARM W/GEAR & SPROCKET
		23	POWER UNIT SUPPORT

Step 6: ATTACHING BRACKETS TO GUIDES

Determine the best method of lifting the curtain coil and brackets to prevent damage to the curtain during installation.

⚠ WARNING: BRACKET AND CURTAIN ASSEMBLY ON LARGER SHUTTERS, PARTICULARLY WITH AN OPERATOR, CAN BE EXTREMELY HEAVY. PERSONS WITH BACK PROBLEMS OR OTHER PHYSICAL CONDITIONS WHICH MAY LIMIT THEM FROM LIFTING HEAVY OBJECTS SHOULD NOT PERFORM THE NEXT STEP.

Lift the coil and brackets to the bracket mounting holes provided on the channel shaped outer guide. Bolt the bracket and guides together as shown in Figure #13, making sure the bracket is positioned inside the guide.

IMPORTANT! THE BOLT HEADS MUST BE ON THE INSIDE (THREADED SECTION OUT) TO PREVENT INTERFERENCE WITH THE OPERATION OF THE COIL.

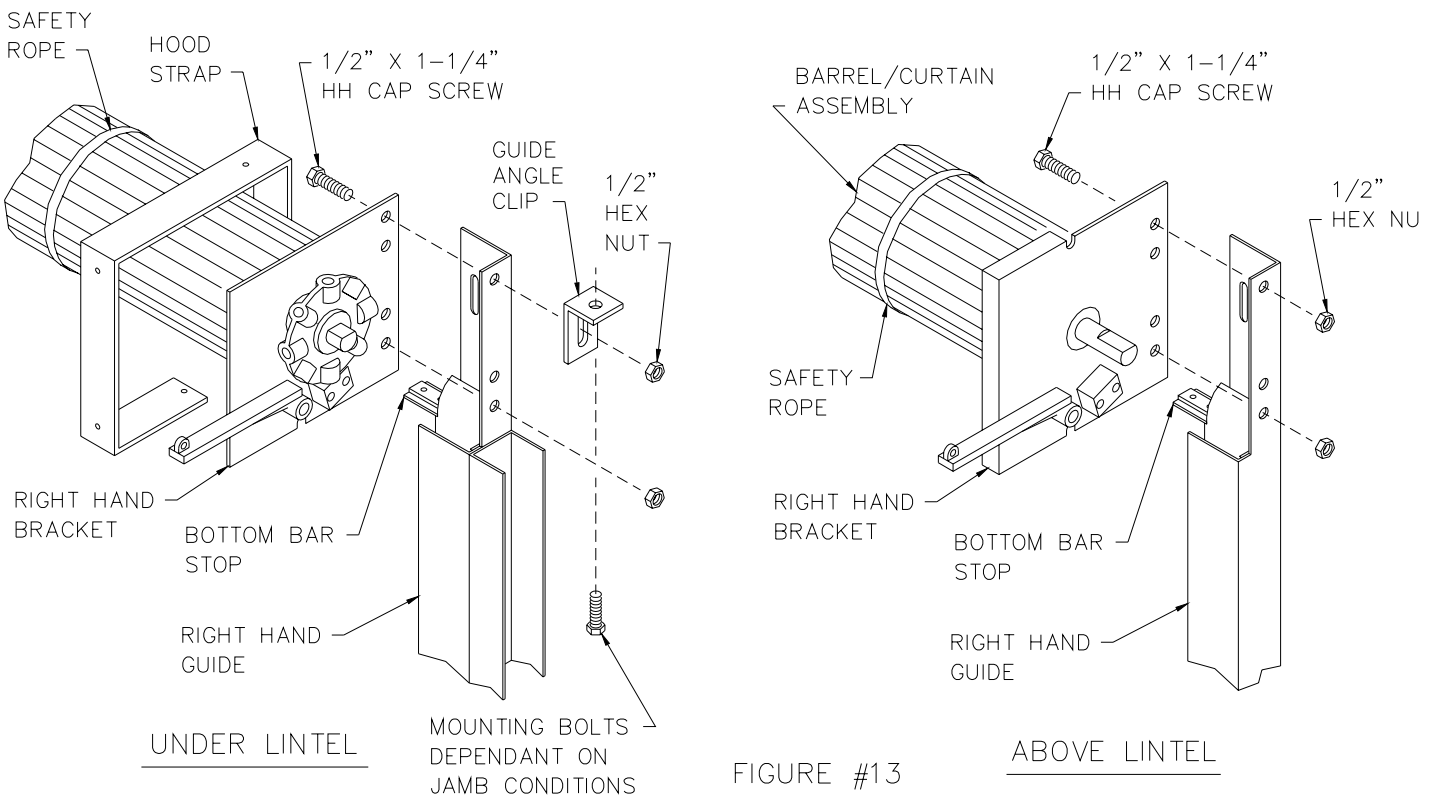

NOTE: POSITION BOTH HOOD STRAPS ON THE COILED CURTAIN.

Loosen the safety rope(s) to let the curtain uncoil until the bottom bar is a few inches below the top of the guides. Block the curtain in place to prevent it from dropping.

⚠ WARNING: DO NOT LET THE CURTAIN FREE FALL. NO TENSION HAS YET BEEN APPLIED TO THE SPRINGS, AND INJURY MAY RESULT.

Step 7: INSTALLING INNER GUIDE ASSEMBLY

Refer to figures 14A and 14B. With the curtain and barrel assembly now mounted to the guides and blocked to prevent curtain from dropping, proceed to install the inner guide assembly. Position the bottom bar inside the channel shaped outer guides approximately 3"-4" below the top of the guide opening.

Position the correct inner guide into the channel shaped outer guide by "hooking" the edge with the holes behind the end of the bottom bar and working it into place so the countersunk holes align with the mating holes in the outer guide. Attach the inner guide using the flat head screws that were shipped installed in the guide assembly.

Repeat this procedure with the opposite guide assembly.

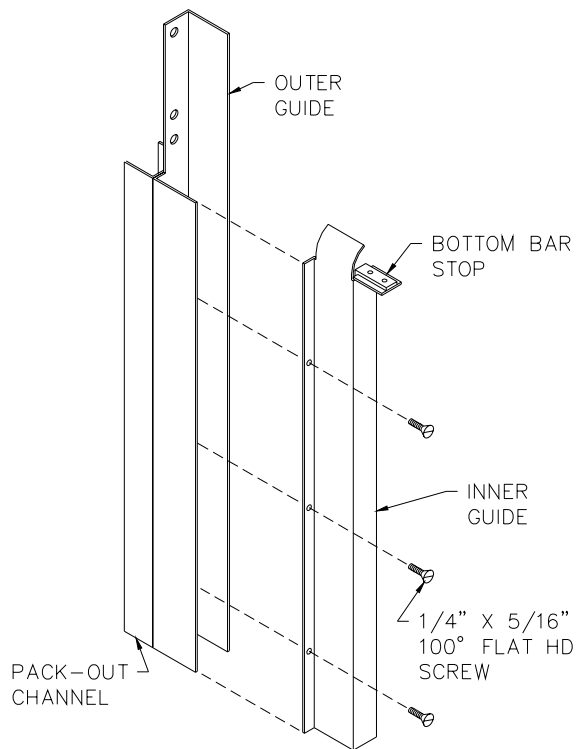

FIGURE #14A

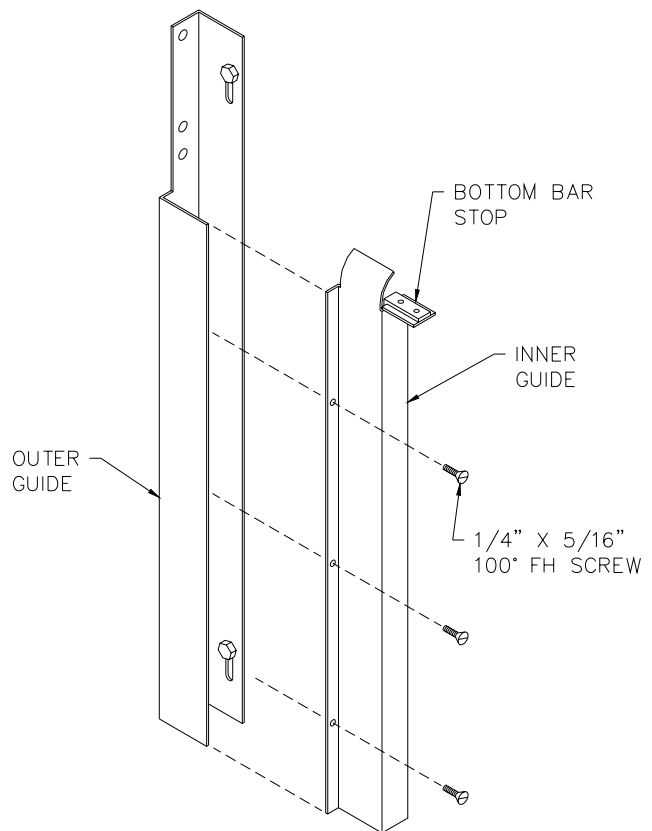

FIGURE #14B

Step 8: APPLYING TENSION

The amount of initial revolutions (IR's) as indicated on the installation drawing and on the barrel "rev tag" is the THEORETICAL STARTING POINT for the required spring tension. In most cases this figure is correct, but due to variations in steel, springs, friction, etc., slight adjustments may be required.

⚠ CAUTION: ALWAYS WIND TENSION WHEN THE SHUTTER IS IN THE UP POSITION. THE SPRINGS ARE UNDER THE LEAST AMOUNT OF TENSION AT THIS POINT.

By hand, rotate the adjusting wheel (AW) slightly in both directions to determine the neutral point of the tension shaft. Using approved winding bar (see tool list in front of manual), insert the two winding rods securely into the holes in the AW as shown in Figure #15.

NOTE: TENSION IS APPLIED IN THE DIRECTION AS THE SHUTTER WOULD TURN AS IT COILS UPWARD (OPPOSITE THE DIRECTION OF THE ARROW ON THE "REV TAG").

⚠ WARNING: TO PREVENT INJURY, WINDING BAR MUST FIT SNUGLY INTO HOLES IN ADJUSTING WHEEL. DO NOT USE LOOSE FITTING BARS OR SCREWDRIVERS WHICH COULD COME LOOSE AND CAUSE INJURY. STAND TO ONE SIDE - NEVER WIND THE SPRING DIRECTLY IN FRONT OF YOU.

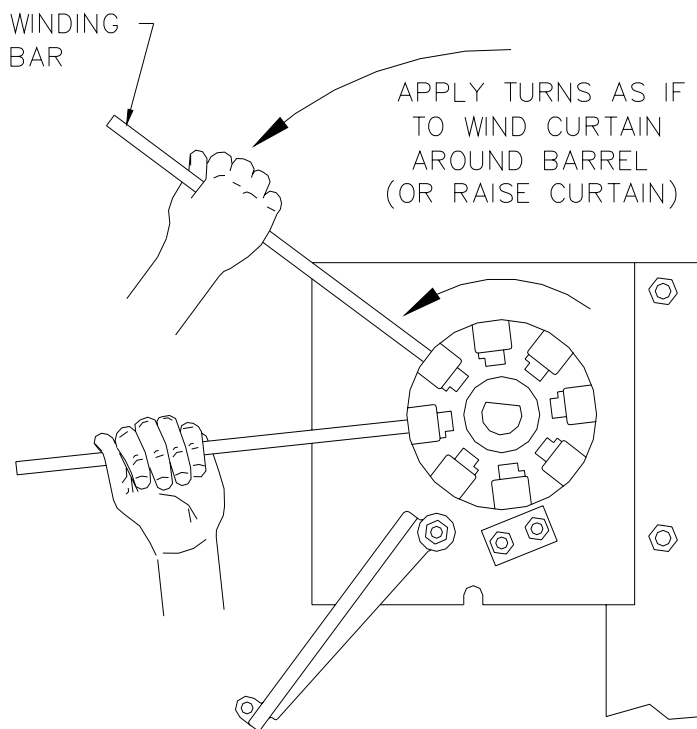

FIGURE #15

Apply the initial revolutions (IR's) marked on the rev tag and installation drawing. The IR's are the required number of turns (of the spring) to hold the curtain in the open position.

HINT: If installation permits, use wall above brackets as brace for winding rod for a safe hands-free procedure of installing the A.W. pin (see Figure 16).

After winding the prescribed amount of initial tension, insert an AW pin into the hole closest forward side of the stop block and secure with a hitch pin (see Figure 16).

⚠ WARNING: EXERCISE EXTREME CAUTION. DO NOT RELEASE THE ADJUSTING WHEEL. INJURY MAY RESULT.

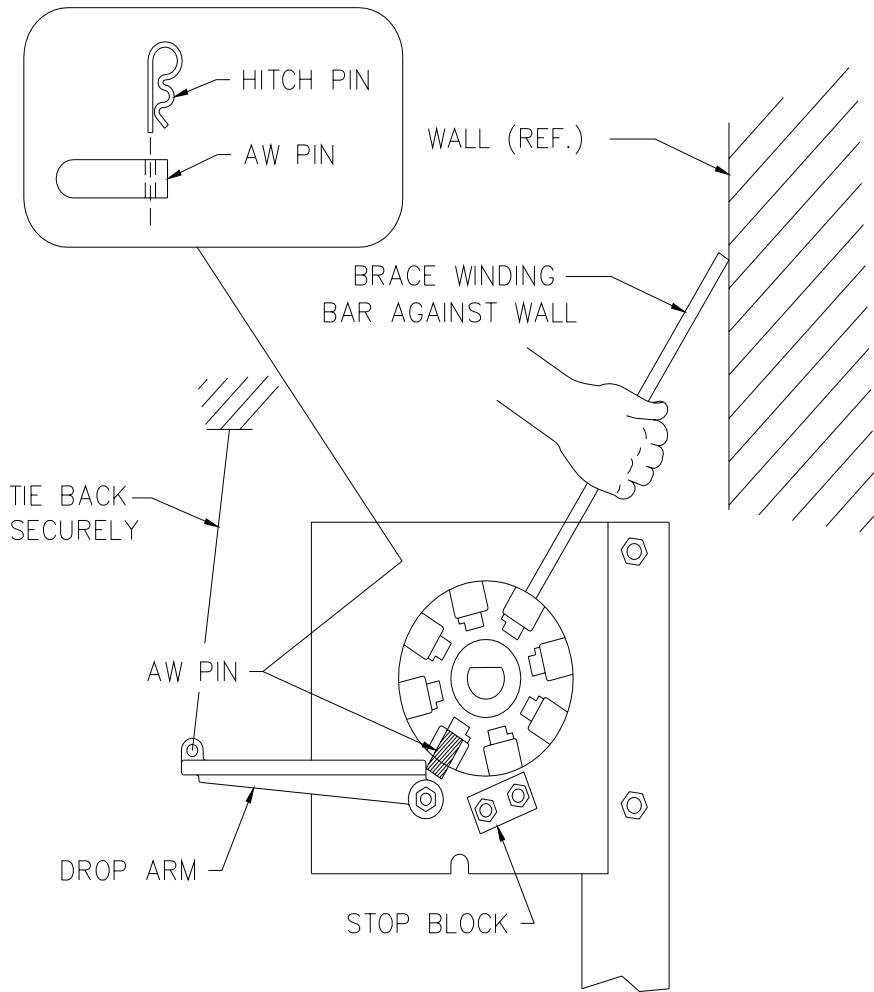

FIGURE #16

With the hitch pin secure, and still holding the winding bar firmly in one hand, raise the drop arm with the other hand to engage the pin. Temporarily tie back the drop arm to block the AW in this position. Remove winding rods. (See Figure #16).

NOTE: THE POSITION OF THE A.W. PIN DETERMINES HOW MUCH TENSION IS RELIEVED WHEN THE DROP ARM IS DISENGAGED, AND IS CRITICAL TO ENSURE THE SHUTTER WILL DROP UNDER ACTUAL FIRE CONDITIONS. THEREFORE, ITS EXACT POSITION WILL BE DETERMINED WHEN THE SHUTTER IS TEST DROPPED.

If a drop ring was provided, locate such that the pin is between the ring pawl and the block. (see Appendix A).

IMPORTANT! APPLY ONLY ENOUGH TENSION TO HOLD THE SHUTTER IN THE UP POSITION AGAINST THE BOTTOM BAR STOPS. THIS IS THE OPTIMUM SETTING, AS TOO MUCH TENSION WILL PREVENT THE SHUTTER FROM DROPPING WHEN TENSION IS RELEASED.

Step 8A: APPLYING TENSION WITH ATLER™ DROP RING

The amount of initial revolutions (IR's) as indicated on the installation drawing and on the barrel "rev tag" is the THEORETICAL STARTING POINT for the required spring tension. In most cases this figure is correct, but due to variations in steel, springs, friction, etc., slight adjustments may be required.

⚠CAUTION: ALWAYS WIND TENSION WHEN THE SHUTTER IS IN THE UP POSITION. THE SPRING(S) ARE UNDER THE LEAST AMOUNT OF TENSION AT THIS POINT.

By hand, rotate the adjusting wheel (AW) slightly in both directions to determine the neutral point of the tension shaft. Before winding the spring make sure that the Atler Drop Ring is positioned on the tension shaft projection between the adjusting wheel and the bracket plate. Also, make sure that the tab on the drop ring is pointing out away from the bracket and that the drop ring is rotated so that the tab is located between the stop block and the drop arm. Using approved winding bars (see tool list in front of manual), insert the two winding rods securely into the holes in the AW as shown in Figure 15.

NOTE: TENSION IS APPLIED IN THE DIRECTION THE SHUTTER WOULD TURN AS IT COILS UPWARD (OPPOSITE THE DIRECTION OF THE ARROW ON THE “REV TAG”).

⚠WARNING: TO PREVENT INJURY, THE WINDING BAR MUST FIT SNUGLY INTO THE HOLES IN THE ADJUSTING WHEEL. DO NOT USE LOOSE FITTING BARS OR SCREWDRIVERS WHICH COULD COME LOOSE AND CAUSE INJURY. STAND TO ONE SIDE - NEVER WIND THE SPRING(S) DIRECTLY IN FRONT OF, OR ABOVE YOU.

Apply the initial revolutions (IR's) marked on the rev tag and installation drawing. The IR's are the required number of turns (of the spring) to hold the curtain in the open position.

HINT : If installation permits, use wall above brackets as brace for winding rod for a safe hands-free procedure of installing the AW pin (see Figure 16).

After winding the prescribed amount of initial tension, insert an A.W. pin into the hole closest to the forward side of the stop block and secure it in position with a hitch pin (see Figure #16).

Once again, insure that the tab on the drop ring is in front of the stop block and that the AW pin is between the drop ring tab and the drop arm (see Figure #16).

⚠WARNING: ALWAYS EXERCISE EXTREME CAUTION WHEN APPLYING OR ADJUSTING SPRING TENSION. DO NOT RELEASE THE ADJUSTING WHEEL. SEVERE INJURY OR DEATH MAY RESULT.

With the hitch pin secure, and still holding the winding bar firmly in one hand, raise the drop arm with the other hand to engage the A.W. pin. Temporarily tie back the drop arm to block the A.W. in this position. Remove winding rods. (See Figure #16).

NOTE: THE POSITION OF THE A.W. PIN DETERMINES HOW MUCH TENSION IS RELIEVED WHEN THE DROP ARM IS DISENGAGED AND IS CRITICAL TO ENSURE THE SHUTTER WILL DROP UNDER ACTUAL FIRE CONDITIONS. THEREFORE, ITS EXACT POSITION WILL BE DETERMINED WHEN THE SHUTTER IS TEST DROPPED.

IMPORTANT! APPLY ONLY ENOUGH TENSION TO HOLD THE SHUTTER IN THE UP POSITION AGAINST THE BOTTOM BAR STOPS. THIS IS THE OPTIMUM SETTING, AS TOO MUCH TENSION WILL PREVENT THE SHUTTER FROM DROPPING WHEN TENSION IS RELEASED.

The function of the drop ring is to increase the amount of tension that the A.W. can remove from the spring. It operates in the following manner. When the drop arm rotates downward, the AW pin will begin to rotate counter-clockwise unwinding the spring. Once the A.W. has revolved 7/8 of a revolution (or turns), it will pick up the tab on the drop ring. Now, it will continue around another 5/8 of a revolution with the drop ring until the drop ring comes into contact with the stop block. At this point 1½ revolutions (or turns) have been removed from the spring. The standard mechanism only removes approximately 7/8 of a turn of tension from the spring.

Step 9: TESTING SHUTTER BALANCE

With the adjusting wheel locked, operate the shutter through several cycles to check shutter balance. If the shutter does not balance properly and requires further spring adjustment, repeat the procedure for "Applying Tension" to add or remove spring tension. Ideally, the shutter should have sufficient spring tension to just allow the shutter to stay up in the open position and no more.

IMPORTANT! INCREASING THE INITIAL TENSION WILL REDUCE THE LIFT EFFORT BUT CAN PREVENT FREE-FALL WHEN REQUIRED TO DO SO UNDER ACTUAL FIRE CONDITIONS.

Step 10: FUSIBLE LINKS AND CABLE ROUTING

Fusible links are designed to melt in the event of a fire and are shipped in a package with the door. The links must be located in such a way that they will be exposed to any fire that may be inside the building.

IMPORTANT! THE LEVERS AT BOTH ENDS MUST DROP REGARDLESS OF WHICH CONNECTION IN THE CABLE SEPARATES.

⚠ CAUTION: PER NFPA 80 FUSIBLE LINKS MUST BE LOCATED NO MORE THAN 18 INCHES BELOW THE CEILING ON BOTH SIDES OF THE SHUTTER OPENING, AND NEAR THE SHUTTER OPENING ON THE SIDE THE SHUTTER IS MOUNTED.

In addition to fusible links, some codes and construction will require the door to be integrated into the building's fire alarm system. This can be done with electro-mechanical devices such as the WayneGuard™. For such devices, see the installation instructions included with them. Generally any fusible link must be at least 6" away from any fixed point (ex: turnbuckle, pulleys etc.) or sufficient enough that the drop out mechanism and tension release arm can swing down (see Appendix D for additional information).

IMPORTANT! A FUSE LINK HOUSING IS REQUIRED IF A DROP CEILING EXISTS ABOVE THE SHUTTER OPENING IN ORDER TO COMPLY WITH THE PROVISIONS OF NFPA 80 AND IN ORDER TO KEEP THE FUSE LINK EXPOSED TO THE HEAT OF A POTENTIAL FIRE, RATHER THAN BEING LOCATED ABOVE THE DROP OR FALSE CEILING

In the event a governor is not provided, dead end cable on opposite side of the wall.

Step 11: TEST DROP

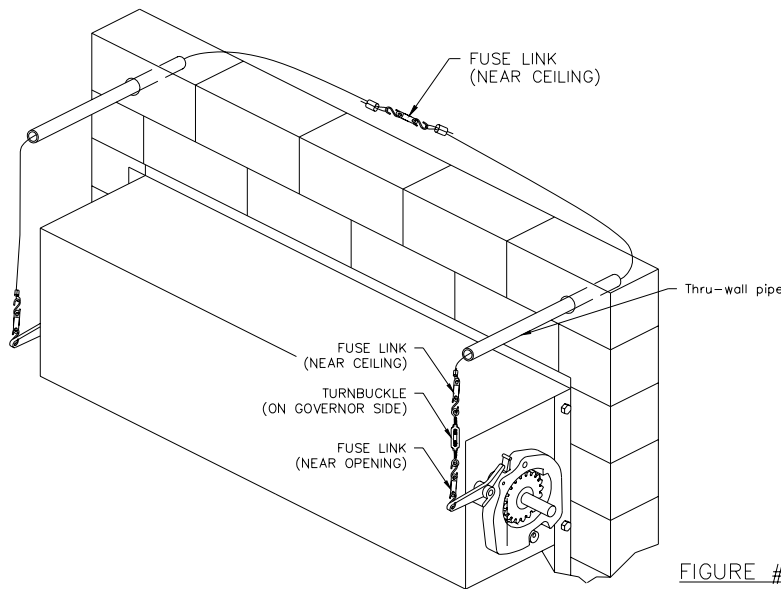

FIGURE #17

⚠ CAUTION: ALWAYS INSTALL TURNBUCKLE AT GOVERNOR (IF PROVIDED) SIDE BRACKET.

Procedure

Prepare to Drop

IMPORTANT! PRIOR TO DROPPING THE SHUTTER, ENSURE THE SHUTTER OPERATES FREELY AND PROPERLY IN NORMAL OPERATION.

Install a second locking pin (see Figure #18) in the adjusting wheel winding hole next to the one against the release lever toward the wall on top. Install hitch pin(s) in hole(s). Spread one loop of the "S" hook on the governor release lever. While holding lever up, slide "S" hook out from release lever. The shutter is now poised to drop.

⚠ WARNING: TO PREVENT INJURY, IF GOVERNOR IS PROVIDED, TEST DROP FROM THE GOVERNOR SIDE OF THE SHUTTER IN ORDER TO AVOID ALL CONTACT WITH THE ADJUSTING WHEEL. THE ADJUSTING WHEEL HAS STORED ENERGY AND IS RELEASED SUDDENLY IN A TEST DROP.

Drop the Shutter

⚠ WARNING: ROPE OFF THE OPENING TO KEEP PERSONS FROM ENTERING AREA DURING TEST DROP. ENSURE ALL PERSONS ARE KEPT CLEAR OF THE OPENING. THE SHUTTER DESCENDS RAPIDLY DURING TEST PROCEDURE AND COULD CAUSE SEVERE INJURY.

⚠ CAUTION KEEP OPENING FREE OF OBJECTS AND DEBRIS. THE SHUTTER COULD STRIKE SUCH OBJECTS CAUSING INJURY OR SHUTTER DAMAGE.

Allow the release lever to drop freely. Record the amount of time the door takes to close and verify it falls between 6 to 24 inches per second. Observe the travel of the adjusting wheel to ensure the locking pin is resting securely against the stop block. Raise door to fully open position several times and repeat procedure to verify it is working correctly. Complete the release form in the back of this manual and return it to the factory.

Step 12: RESETTING PROCEDURE

Open the Shutter

⚠️ WARNING: DUE TO RELEASE OF SPRING TENSION SHUTTER MAY BE EXTREMELY HEAVY. PERSONS WITH BACK PROBLEMS OR OTHER PHYSICAL CONDITIONS WHICH MAY LIMIT THEM FROM LIFTING HEAVY OBJECTS SHOULD NOT PERFORM THIS NEXT STEP.

On manually operated doors, raise the door to the open position and clamp or block open. Some doors (larger than 8'x10') may require mechanical assistance to lift open, or require rewinding a portion of the spring tension that was released (see Step 9). On mechanically operated doors, re-engage the gear mechanism by temporarily tensioning the release cable at the drive end of the door.

⚠️ WARNING: KEEP HANDS, ARMS AND CLOTHING FREE OF MESHING GEARS. MECHANISM AND GEARS MOVE FREELY AND QUICKLY SO THAT THEY COULD CAUSE SERIOUS INJURY.

Proceed to raise the door using the mechanical operator. Block or clamp the door in the open position.

NOTE: ON MOTOR OPERATED SHUTTERS IF ELECTRICAL POWER IS AVAILABLE, DEPRESS THE DOWN BUTTON PRIOR TO ENGAGING GEAR MECHANISMS. THIS WILL ELIMINATE THE NEED TO RESET THE LIMIT SWITCHES.

Retension the Springs (see Step #8, page 14 for picture representation)

⚠️ WARNING: WINDING BAR MUST FIT SNUGLY INTO HOLES IN ADJUSTING WHEEL. DO NOT USE LOOSE FITTING BARS OR SCREWDRIVERS WHICH COULD COME LOOSE AND CAUSE INJURY.

Proceed to replace all initial tension by rotating the adjusting wheel in the direction the door coils UP so that the first locking pin is now just beneath the release lever.

If the door has a drop ring on it, it will be necessary to rotate the adjusting wheel in the direction that the door coils up until the AW pin comes into contact with the drop ring tab and then back around until the pin and the drop ring tab are beneath the drop arm (release lever). See Step 8A and Figures 15 & 16 for more information.

⚠️ WARNING: KEEP HANDS, ARMS AND CLOTHING FREE OF ADJUSTING WHEEL. STORED ENERGY COULD BE RELEASED SO AS TO ROTATE THE ADJUSTING WHEEL SUDDENLY WHICH COULD CAUSE INJURY.

While holding the release lever up, re-insert the "S" hook and bend the loop to prevent the hook from accidentally coming off. Ensure all cables and "S" hooks at attachment points are secure.

Restore Cable Tension

Restore adequate cable tension (by using turnbuckles provided) to keep release levers in place and to engage gears (if required).

NOTE: TOO MUCH CABLE TENSION MAY INTERFERE WITH NORMAL OPERATION OF SHUTTER.

Check Shutter Operation

Push (or operate) the door up and down several times. Observe the governor end. Listen for any ratcheting noise. If there is any noise, increase the cable tension.

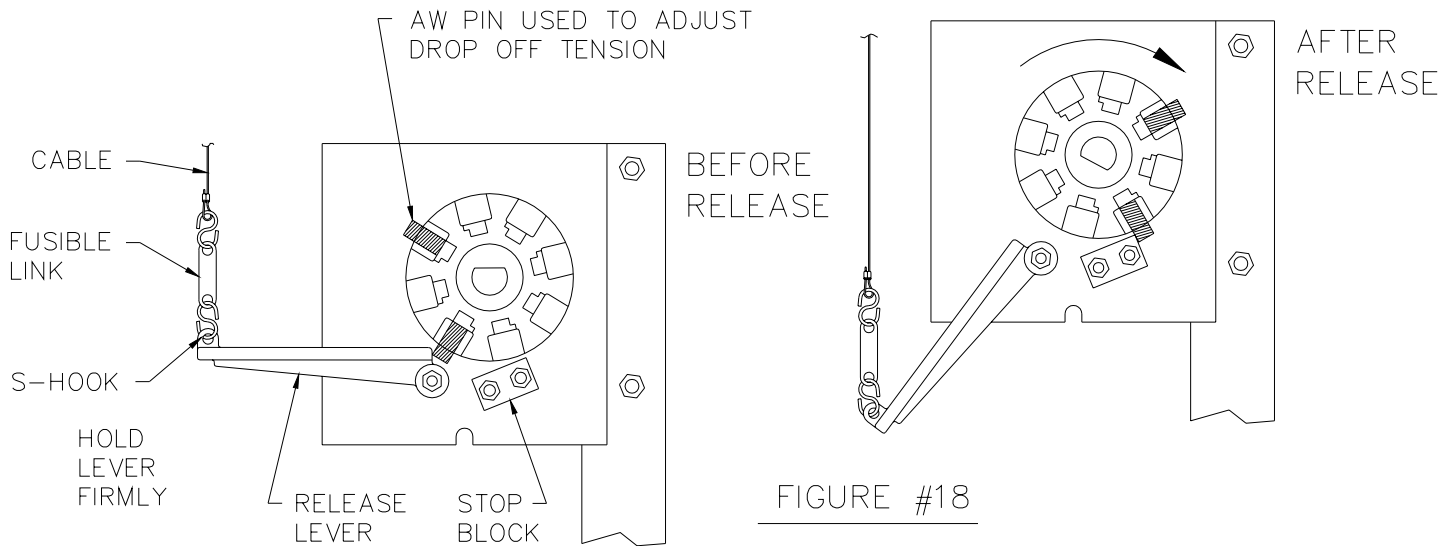

Step 13: HOODS, SUPPORTS & HOUSINGS (UNDER LINTEL)

(Skip to next section for brackets mounted above lintel)

HINT: LOWER THE SHUTTER TO OFFER THE MAXIMUM CLEARANCE BETWEEN THE COIL AND THE LINTEL. REFER TO FIGURE #19 AND #20. INSTALL THE FLAME BAFFLE AND HOOD STRAPS IN THE LINTEL HOLES PREPARED EARLIER. TEST THE FLAME BAFFLE FOR FREEDOM OF MOVEMENT. IT SHOULD HAVE THE ABILITY TO SWING DOWN AND REST ON THE BARREL/COIL ASSEMBLY WITHOUT RESTRICTING DOOR OPERATION.

IMPORTANT! THE FRONT HOOD MAY CONTAIN A FLAME BAFFLE FUSIBLE TAB LOCATED INSIDE. THE FLAME BAFFLE (IF PROVIDED) MUST REST ABOVE THIS TAB AND BE CONTAINED BY IT (see Figure #20).

NOTE: NFPA 80 DOES NOT APPROVE THE USE OF LEAD ANCHORS ON ROLLING FIRE SHUTTER INSTALLATIONS; DO NOT USE LEAD ANCHORS.

Temporarily prop the flame baffle in its upper-most position before attaching the front hood. This will insure it is guided into this position. Remember to remove the props later. Position the front hood on the hood straps. Align and punch all holes in the hood at the hole locations in the hood straps. Attach the front hood with the self-tapping screws provided, but do not tighten the screws at this time, since the housings must slide under the front hood.

HINT : IF DOOR IS MOUNTED TOTALLY UNDER THE LINTEL AND THE FASCIA SIDE IS ACCESSIBLE, IT MAY BE EASIER TO INSTALL THE FRONT HOOD FIRST, THEN SLIDE IN THE FLAME BAFFLE (IF REQ'D) FROM THE FASCIA SIDE.

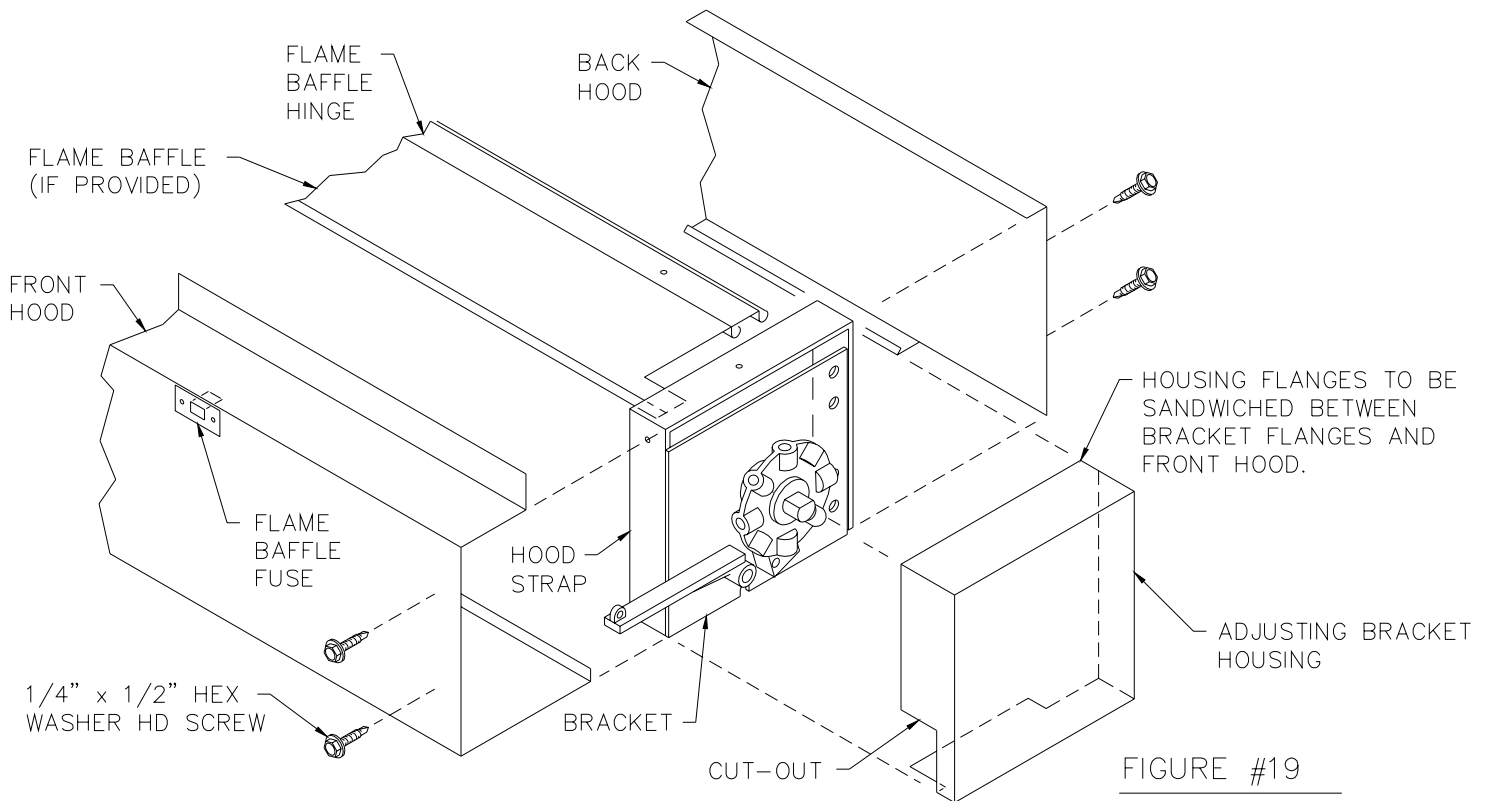

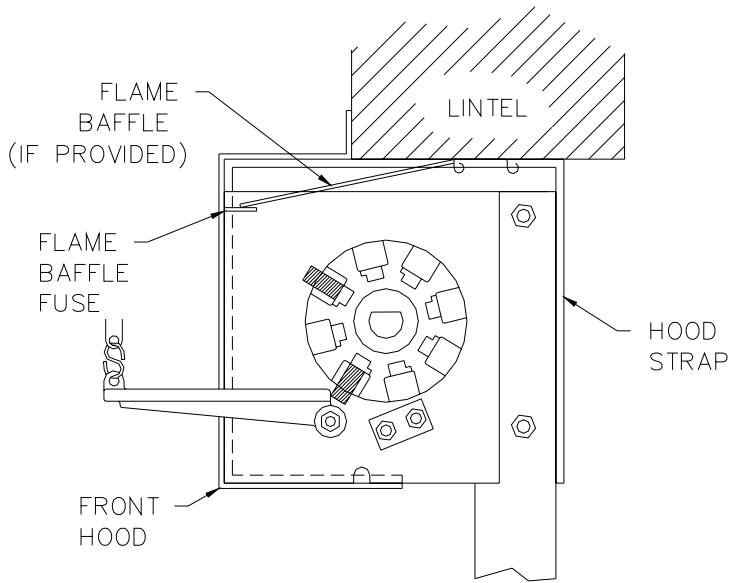

FIGURE #20

Attach the A.W. bracket housing and sandwich the flanges between the hood straps and the front hood (see Figure #21). Check to insure the cutouts, as provided, are large enough so as not to interfere with either drop arm throughout its travel. Trim if necessary. Now tighten all screws in the vicinity of AW bracket locking hood/housings in place. Attach the governor bracket housing in similar manner, and proceed to tighten all remaining hood screws. Remove temporary flame baffle props, making sure only the fusible tab holds the baffle in its upper position.

Proceed to attach the back hood to the hood straps. Align and punch all holes in the back hood at the points where holes are provided in the hood straps.

Hoods, Supports & Housings (above lintel)

HINT: LOWER THE SHUTTER TO OFFER THE MAXIMUM CLEARANCE BETWEEN THE COIL AND THE LINTEL.

Refer to Figure #21. A front hood retainer is required to secure the top flange of the front hood. It is positioned along the face of the wall and is notched in order to be slid behind the top guide-to-wall mounting bolts (see Figure #21). After the retainer is in place, raise the front hood and set it over the brackets.

IMPORTANT! THE FRONT HOOD MAY CONTAIN A FLAME BAFFLE FUSIBLE TAB LOCATED INSIDE. THE FLAME BAFFLE (IF PROVIDED) MUST REST ABOVE THIS TAB AND BE CONTAINED BY IT (See Figure #21 inset).

Fasten the hood to the existing holes in the bracket flanges using the self-tapping screws provided. Do not tighten screws at this time, since the housings must slide under the front hood. The flange of the hood retainer can now be bent down 90 degrees to cover the top flange of the front hood (see Figure #21 inset).

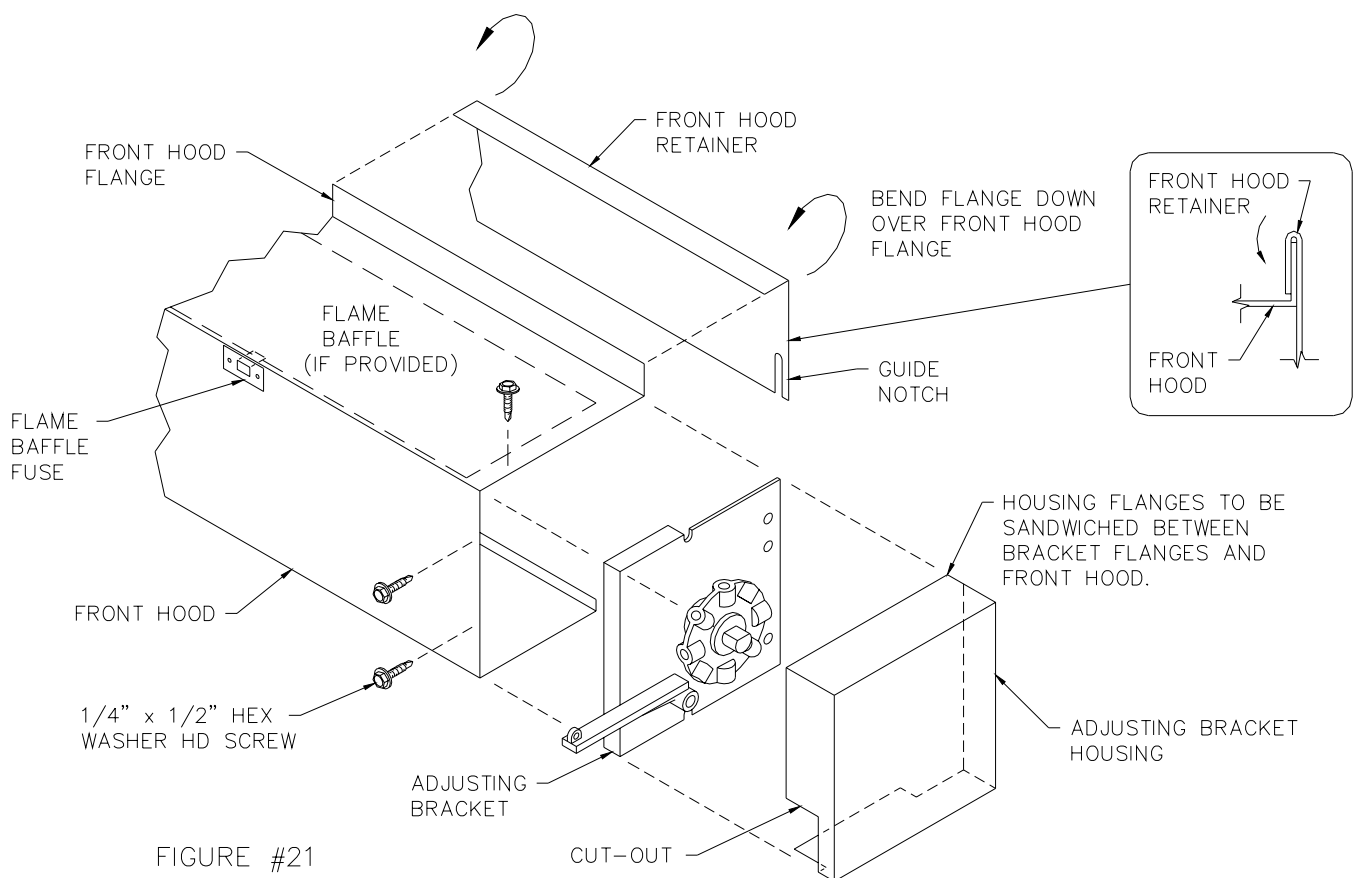

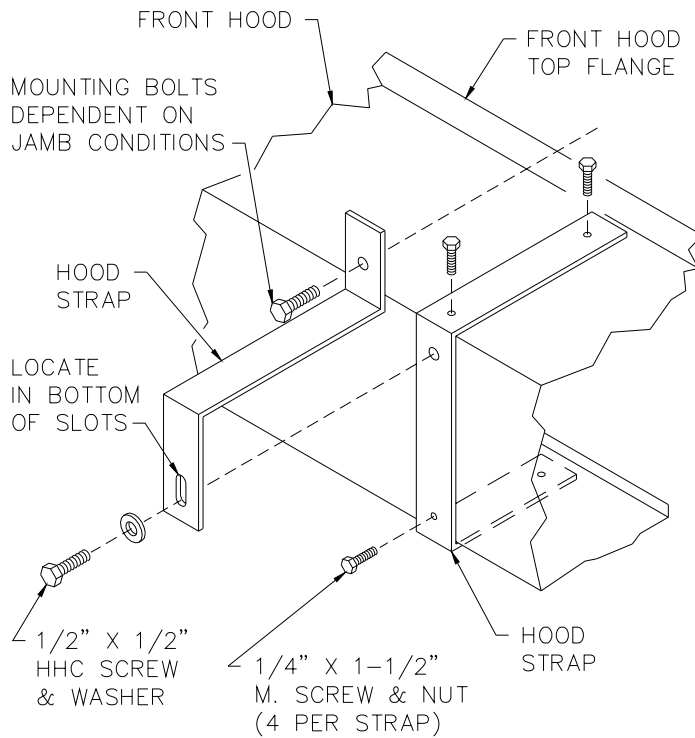

FIGURE #22

Refer to figure #22. Depending on the width of the hood, extra supports may be required. If hood straps are provided, erect them now. To allow for thermal expansion, locate the connecting screws in the bottom of the slots.

Attach the A.W. bracket housing and sandwich housing flange between bracket flange and front hood (see Figure #21). Check to insure the cut-outs, as provided, are large enough so as not to interfere with either drop arm throughout its travel. Trim if necessary. Now tighten all screws in the vicinity of A.W. bracket. Attach the governor bracket housing in similar manner and proceed to tighten all remaining hood screws.

Appendix A: Optional Components

The following are some examples of common options and adjustments for fire doors:

SLIDE BOLTS OR CYLINDER LOCKS

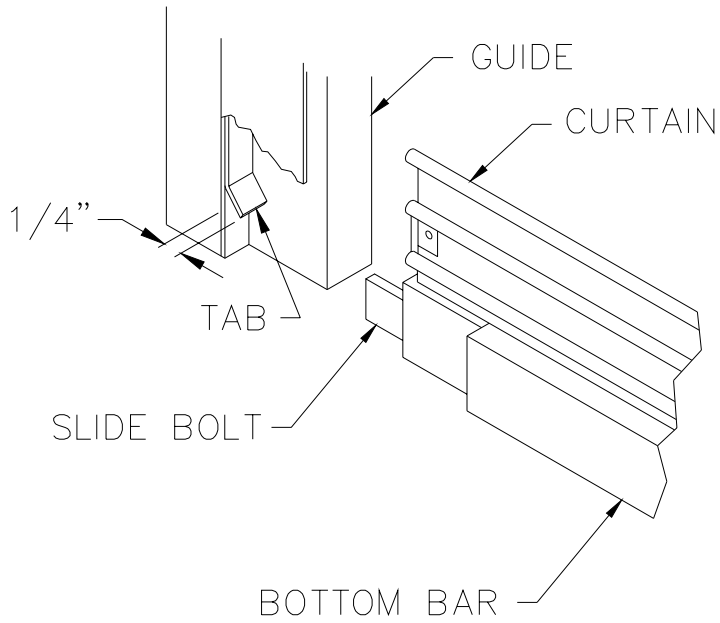

Raise the shutter to the open position. Bend the tab on the inside of the guides so that it sticks out about 1/4". Lower the shutter and try to engage the locks. If the bottom bar contacts the tab before the door is completely closed, or the locks still do not engage the tab, bend the tab back in so that the casting just clears.

Appendix C: Trouble Shooting

The chart below is a list of possible problems with the operation of the fire shutter. The probable causes listed are the most common, and are not meant to include ALL possibilities. With the variety of the product and the field conditions, other factors may be involved.

TROUBLE	PROBABLE CAUSE	REMEDY
Shutter raises hard, closes easily	Insufficient counterbalance	Increase spring tension (see Step 8)
Shutter closes hard, raises easily	Too much counterbalance	Decrease spring tension (see Step 8)
Shutter jumps up from counter	Too much counterbalance	Decrease spring tension (see Step 8)
Curtain runs to one side	Broken end-locks Barrel not level	Check and replace Check and level barrel
Shutter sticks when closing	Bent guide angle(s)	Inspect for bent or kinked guides. Straighten guides and check width of groove.
Shutter coil makes cracking sound	Bent slats	Inspect, remove and straighten or replace
Shutter squeaks when operating	Tight guides Dirty guides	Check alignment and distance between guides. Inspect and clean inside of guide. Do not lubricate with grease. Use WD-40 or silicone spray.
Shutter is difficult to raise, will not stay open	Broken spring or wrong hand springs	Remove barrel and replace spring.
Motor runs, Shutter does not operate	Curtain jammed	Inspect and remove obstruction.
Door Won't Drop	Drop Ring Not Installed Properly	Review Steps 5 thru 9

Appendix D: Additional Fusible Link Cabling

Below are additional details for fire shutters with the coil mounted above ceiling, or a typical modification for electro-mechanical release devices. Also provide are alternative fuse link cable routings. These are provided as a sample and may not be right for every installation. The actual field condition at the job site will determine the best cable routings. If you need help determining a cable routing for your installation contact Wayne-Dalton Technical Service for assistance.

TYPICAL DETAIL FOR COIL MOUNTED ABOVE CEILING

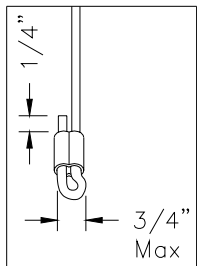

DETAIL OF CABLE LOOP REQUIREMENT (TYPICAL EACH LOCATION THAT REQUIRES LOOP TO GO THROUGH PIPE OR CEILING FUSE BOX)

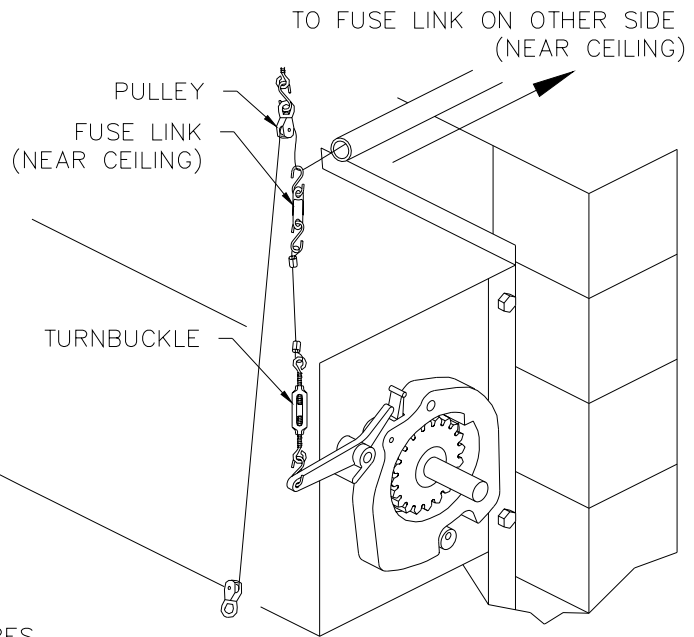

CAUTION – ALWAYS INSTALL TURNBUCKLE AT GOVERNOR SIDE BRACKET

TYPICAL DETAIL FOR ELECTRO-MECHANICAL DEVICES

SEE STEP 10 FOR ADDITIONAL INFORMATION AS TO LOCATION OF FUSIBLE LINKS AND ADJUSTER SIDE BRACKET

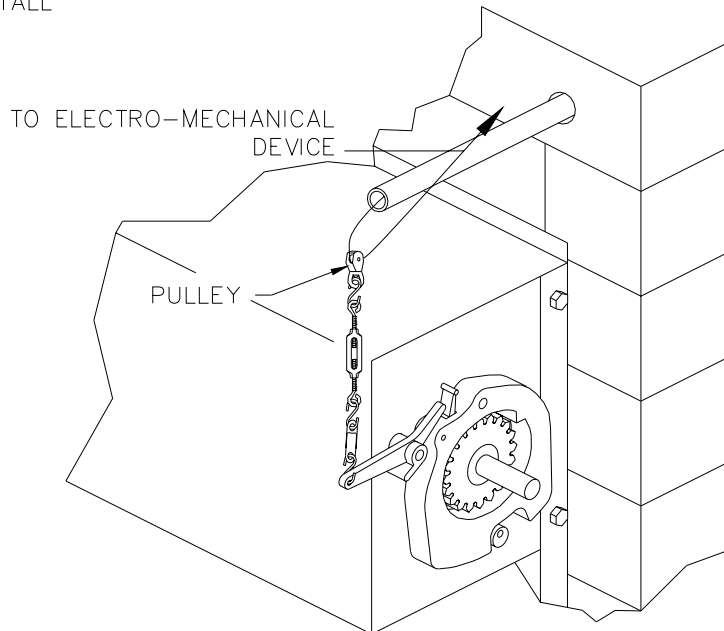

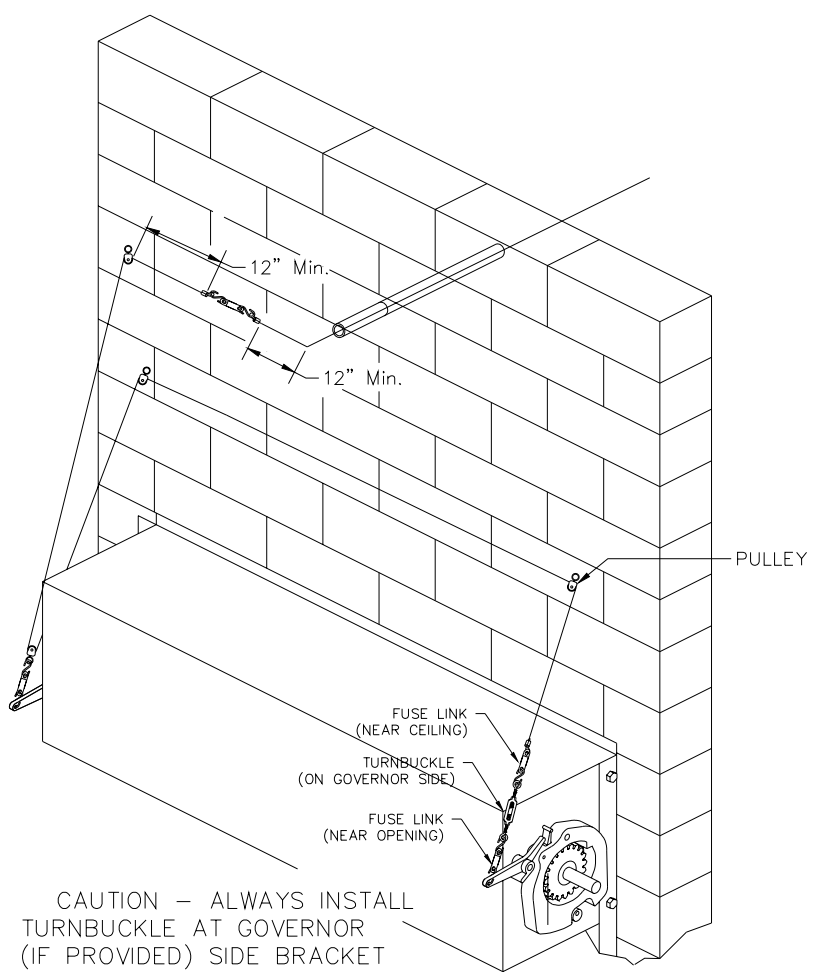
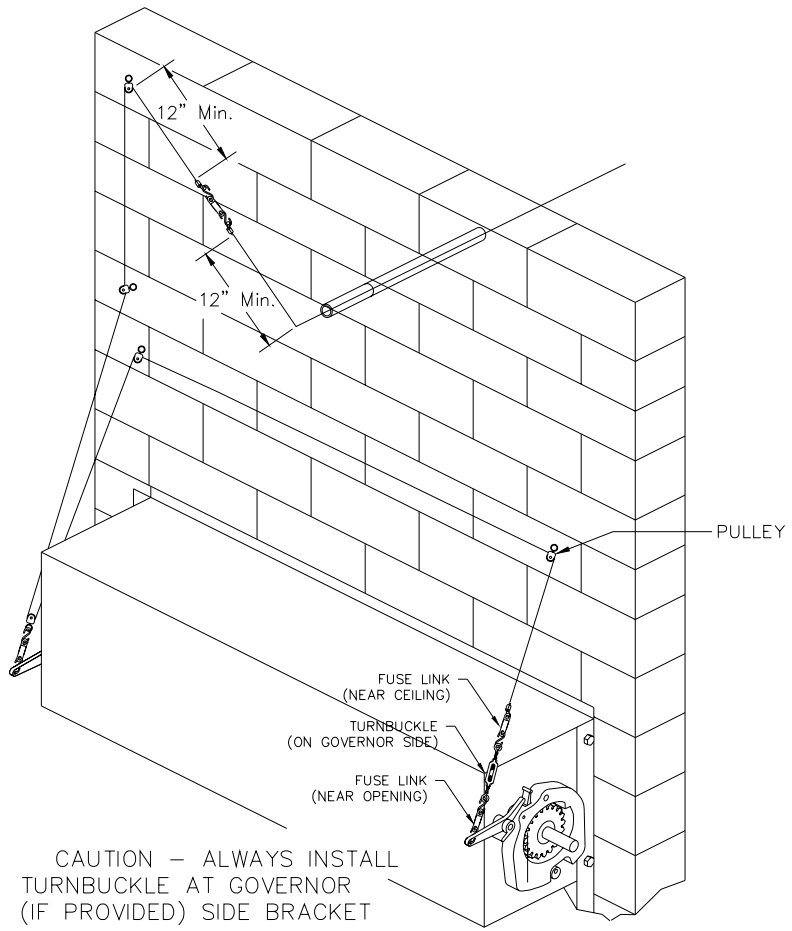

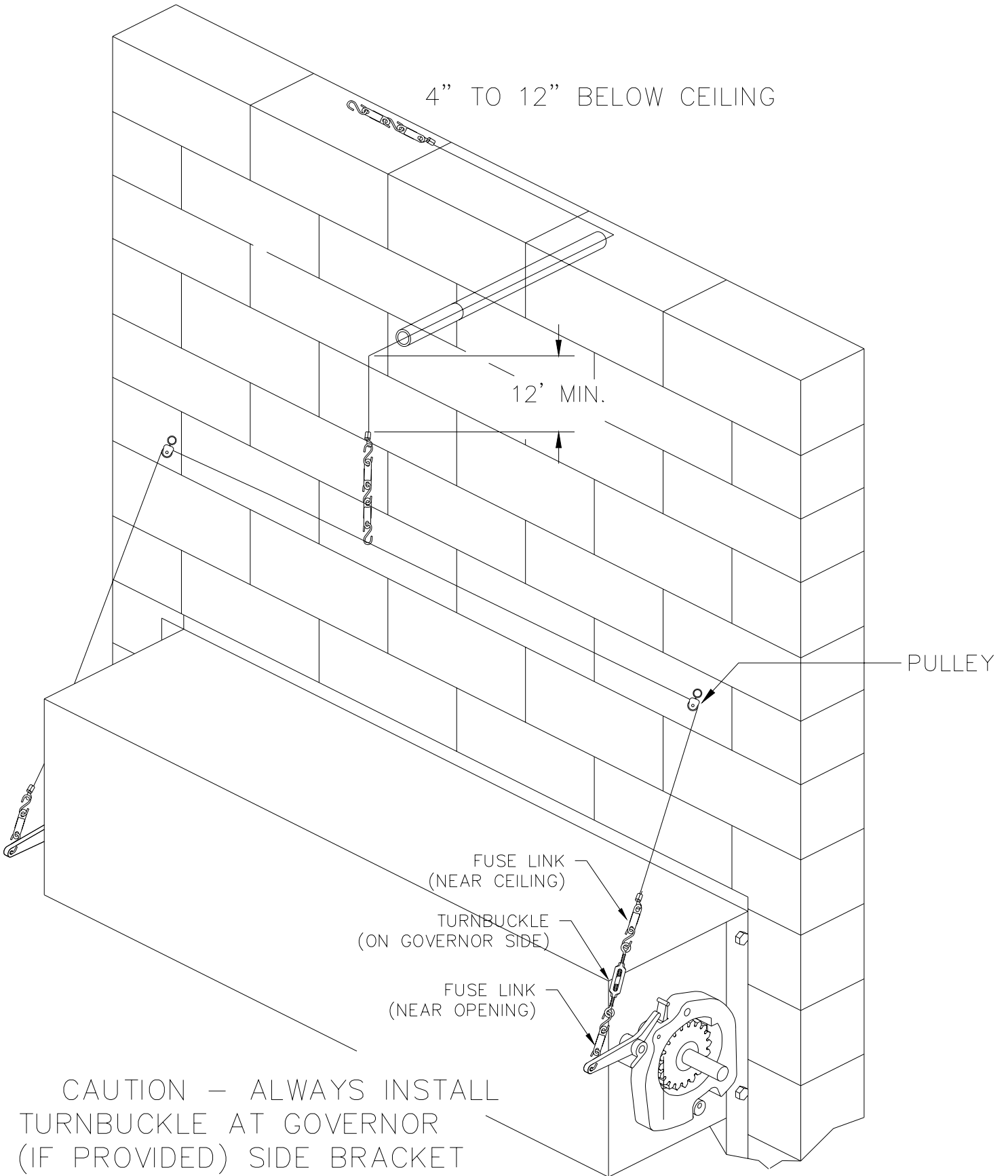

4" TO 12" BELOW CEILING

12' MIN.

PULLEY

FUSE LINK
(NEAR CEILING)

TURNBUCKLE
(ON GOVERNOR SIDE)

FUSE LINK
(NEAR OPENING)

CAUTION — ALWAYS INSTALL
TURNBUCKLE AT GOVERNOR
(IF PROVIDED) SIDE BRACKET

Appendix E: Drop Tests and Annual Inspection.

Wayne Dalton Provides a 3 part form titled Rolling Door Drop Test Form and Annual Inspection. This form provides guidelines for inspecting and testing fire products. The form also provides space to record each test and inspection that occurs. The guidelines provided may be incomplete for some installations. A sample of the form is provided. If you did not receive a form or need more forms contact your Wayne-Dalton Customer Service Representative. The part number of this form is 101-0079-04.

WAYNE-DALTON CORPORATION ROLLING FIRE DOOR DROP TEST FORM AND ANNUAL INSPECTION

NOTE TO OWNER: NFPA-80 requires the annual testing of rolling fire doors to demonstrate proper and full closure. Resetting of the release mechanism must be done in accordance with the manufacturer's instructions. A written record must be maintained and made available to the authority having jurisdiction. NFPA-80 also requires that when damage impairs the door's proper emergency function, that it be repaired with parts obtained from the original door's manufacturer and upon completion of repairs that the door be tested to assure emergency operation and closing.

WARNING: SEVERE INJURY OR DEATH MAY RESULT THROUGH IMPROPER ATTEMPTS AT DROP TESTING, REPAIR AND/OR MAINTENANCE.

Drop testing, repair and/or maintenance should be performed by qualified personnel with a complete knowledge and understanding of this type of door. Before drop testing, conduct a visual inspection for damaged or missing parts that may create a hazard during testing or affect proper operation or resetting. Verify proper installation. Open and close the door to check for correct spring tension. ADDITIONAL INFORMATION ON DROP TESTING IS PROVIDED ON THE REVERSE SIDE OF THIS FORM, IN THE MANUFACTURER'S INSTALLATION/RESET INSTRUCTIONS, AND IN NFPA-80.

PROJECT _____ CONTACT PERSON _____
 ADDRESS _____ PHONE _____
 _____ DATE _____

Door # Location	Door Size	Door Serial No.	U.L. Tag No.	Visual Check		Operation Check		Visual check	
				Pass	Fail	Pass	Fail	Pass	Fail
1.									
2.									
3.									
4.									

New Installation _____ Annual Check _____

COMMENTS AND RECOMMENDED WORK (new form needed when work is completed)

Door #1 _____

Door #2 _____

Door #3 _____

Door #4 _____

The doors listed above (noted as "passed" for the drop test) have been installed in accordance with the manufacturer's installation instructions. The automatic release device has been tested to demonstrate proper operation and full closure. They have been reset in accordance with the manufacturer's reset instructions and left in proper working condition, unless otherwise noted above.

TESTED BY _____

WITNESSED BY _____

COMPANY _____

REPRESENTING _____

ADDRESS _____

SIGNATURE _____

RECOMMENDED WORK IS: Authorized _____ Declined _____

SIGNATURE _____

DATE _____

BY _____

SUGGESTED INSPECTION AND DROP TEST GUIDELINE ON REVERSE SIDE

INSPECTION AND DROP TEST GUIDELINES

Refer to the manufacturer's installation/reset instructions and NFPA-80

VISUAL INSPECTION

⚠️ CAUTION: EVERY COMPONENT OF A DOOR AND ITS INSTALLATION MUST BE CHECKED FOR DETERMINATION OF FACTORS THAT MAY AFFECT A DOOR'S INTENDED OPERATION AND PERFORMANCE. THE LIST BELOW MAY BE INCOMPLETE AND IS PROVIDED AS A GUIDELINE ONLY.

A. Proper installation requirements

1. Curtain, barrel and guides must be aligned level, plumb, and true
2. Attachment to jambs must be with proper bolts, expansion anchors, or as otherwise required by the listing
3. Maintain expansion clearance (bottom of guides for Akbar 89, top of guides for Adler)
4. Fusible links must be located at top of door and within 1 foot of ceiling on both sides of wall

B. Check and repair damaged, incorrect or missing parts, such as:

1. Slats - bent slats, cracked beads, torn ends
2. Endlocks - missing, broken, bent, loose
3. Bottom bar - bent angles, loose bolts, missing washers on bolts (when required)
4. Guide assembly - bent angles, loose bolts, missing galvanized washers or bolts (when required) Curtain entry or debris in guide
5. Hood and flame baffle (when baffle required) - bent, rubbing curtain in open position, holes, tears. Attachment to brackets and wall (when required), intermediate supports (when required)
6. Brackets and operating mechanisms - worn, misaligned or badly meshed gears, broken parts, and bent shafts
7. Automatic closing and governor mechanisms - missing or broken parts, drop or release arms tied, blocked, or wedged
8. Fusible links, cable, S-hooks, eyes, pulleys, etc. - links painted or coated with dust or grease, kinked or pinched cable, twisted or not flexible, obstructed eyes or raceways
9. Mounting and assembly bolts - missing or loose (if welded, are welds done per specs)
10. Guide mounting bolts must all be in bottom of slot for downward expanding Akbar 89 fire doors and top of slot for upward expanding Adler fire shutters
11. Past replacement of parts not from the original door manufacturer - "homemade" or mismatched parts are not approved and must be replaced.
12. Check balance and spring tension of door
13. If chain operated, check hand chain for damaged links. Replace or repair if necessary
14. If motor operated, check door operating jamb sprocket and chain, adjust and lubricate as necessary. Readjust limits as necessary.

C. Ancillary equipment

1. Smoke detectors/release devices - check continuity (all release devices must be tested)
2. Control panels - check function
3. Miscellaneous other equipment should be checked for proper function and operation

⚠️ WARNING: SERVICING OF MOTOR OPERATOR SHOULD BE DONE BY A QUALIFIED ELECTRICIAN WITH THE NECESSARY SCHEMATICS AND PROPER KNOWLEDGE OF THE OPERATOR.

OPERATIONAL INSPECTION

Roll door up and down in normal operation to check for spring tension and free movement of curtain in guides.

DROP TEST

If the shutter does not roll up and down properly in normal operation, or if there are damaged or missing parts that will create a hazard or prevent proper operation or reset, THESE CONDITIONS MUST BE CORRECTED BEFORE CONDUCTING A DROP TEST.

Drop test per manufacturer's instructions. Drop test should provide for automatic closing of the curtain at an average speed not less than 6 inches per second, nor more than 24 inches per second, and full closure of the curtain with the bottom bar closing evenly across the sill/floor.

Reset per manufacturer's instruction. Complete drop test forms and forward copies to Wayne-Dalton dealer and customers.

ULTIMATE ACCEPTABILITY OF A FIRE DOOR IS THE DECISION OF THE AUTHORITY HAVING JURISDICTION, AS DEFINED BY NFPA-80.