

for light commercial and industrial swing-leaf gates

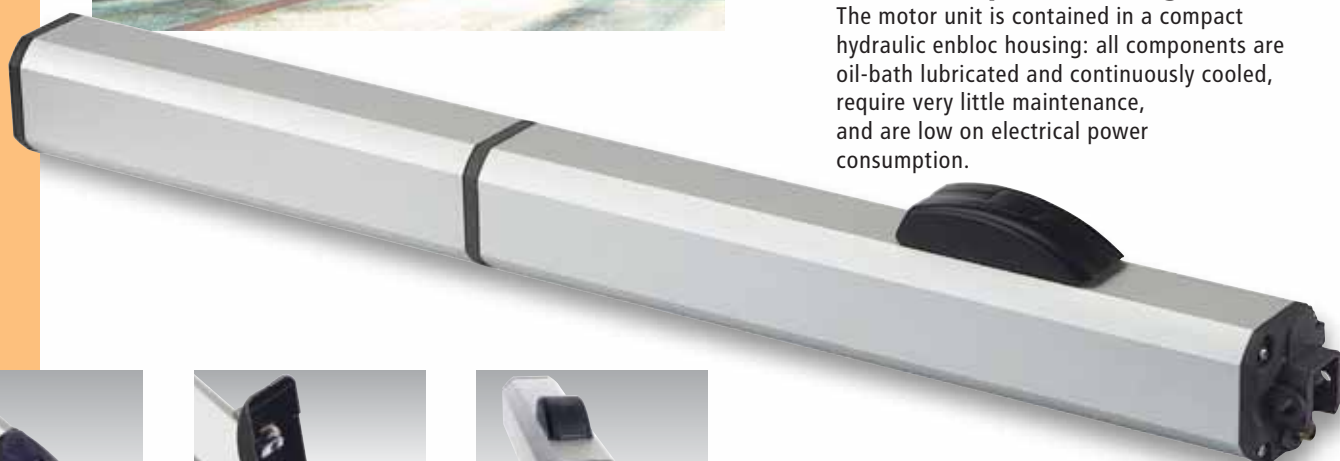

■ Key-operated emergency release



■ Key-operated emergency release



■ Co-moulded cable

■ A wide range of models

The FAAC 400 offers a range of 7 different operators, with or without hydraulic locking designed to automate swing gates up to 7 metres per leaf. The whole range is easily installed and models are available for very heavy gates, industrial gates and high frequency operators.

■ Safe both inside and out

The exclusive hydraulic device, ensuring maximum anti-crushing protection, features two highly sensitive by-pass valves. In case of an emergency, a customised release key makes it possible to operate the gate manually. The power of hydraulic locking gives the system exceptionally high resistance against break-in attempts.

■ FAAC'S experience is guarantee

The motor unit is contained in a compact hydraulic enbloc housing: all components are oil-bath lubricated and continuously cooled, require very little maintenance, and are low on electrical power consumption.

■ Reliability and low noise

Precision mechanics and use of hydraulic oil as motor fluid are the secrets behind the extremely low noise movement. Reliability is assured under any atmospheric conditions and at extreme temperatures in the range -40° C to +55° C.

SPECIFICATIONS

Hydraulic operator with piston for swing-leaf gates • Models available with hydraulic locking on closing, opening and closing, and without locking • Models suitable for max leaf length up to 7 m • Models with max use frequency up to 50 cycles/hour • Models with max traction/thrust force up to 775 daN • Models with rod extension speed 1 cm/s and 1.5 cm/s • Models with pump flow rate of 0.75 - 1 - 1.5 l/min • Models with rod effective stroke 280 mm and 380 mm • Pillar installation • Leaf opening inwards or outwards • Max opening angle 120° • Electric motor power supply 115/230V (+6%-10%) 50(60) Hz • Electric motor power 220 W • Thermal protection at 120°C built into motor winding • Overall dimensions (Length x Width x Height) 1.031x90x113 mm • Protection class IP 55 • Operating ambient temperature -40°C ÷ +55°C • Built-in release device with customised key • Single-phase motor with two rotation directions (1.400 rpm) • Hydraulic gerotor pump (max low noise) • Die-cast distribution flange • Separate control of opening and closing force by by-pass valves • Rod in stainless steel • Securing to front fitting by ball joint • Tank and piston protective housing in anodised aluminium • Air breather screw • Mineral hydraulic oil



- 1 Rod protective housing
- 2 Key-operated emergency release
- 3 Oil tank



INSTALLATION LAYOUT

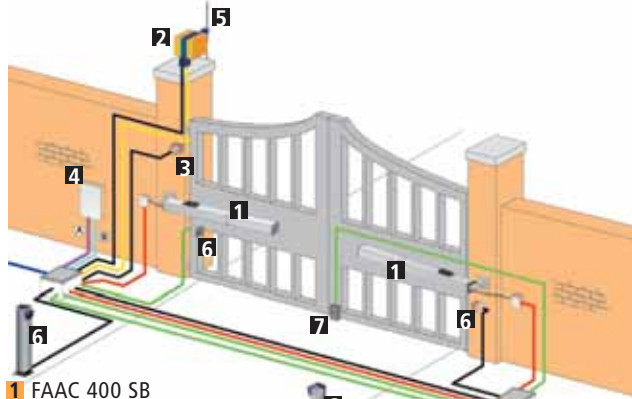

- 1 FAAC 400 SB
- 2 FAAC LIGHT
- 3 FAAC T10
- 4 FAAC 452 MPS/MINIDEC DS
- 5 FAAC PLUS 1 433
- 6 FAAC FOTOSWITCH
- 7 ELECTRIC LOCK

Low voltage cabling	Power cabling (115/230V)
(A) { <ul style="list-style-type: none"> nr.4 cables 3x0,5 nr.3 cables 2x0,5 	(B) { <ul style="list-style-type: none"> nr.2 cables 3x1,5+T nr.1 cable 2x1,5+T nr.1 cable 2x1,5

N.B: Cable diameters in mm²

DIMENSIONS

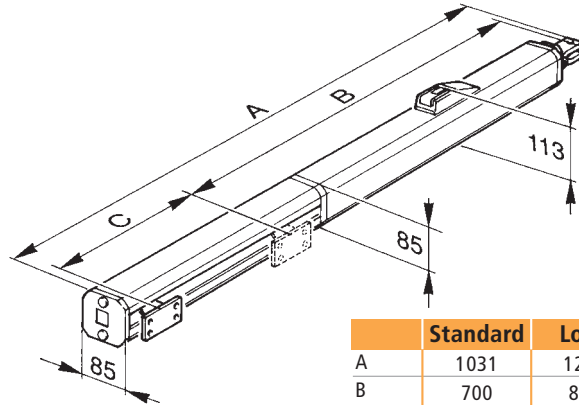

	Standard	Long
A	1031	1285
B	700	822
C	260	380

Values in mm

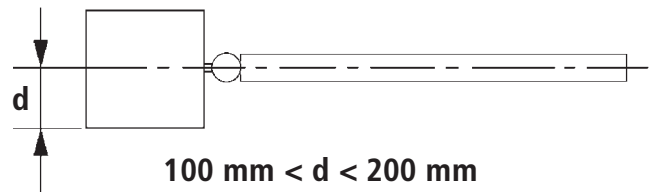

Technical specifications	400 CBC	400 CBAC	400 SB	400 SBS	400 CBACR	400 CBAC LN	400 SB LN
Power supply	115/230 Vac (+6% -10%) 50 (60) Hz						
Absorbed power	220 W						
Absorbed current	1 A						
Motor rotation speed	1400 rpm						
Rod extension speed	1 cm/s		0,75 cm/s		1,5 cm/s		
Pump flow rate	1 l/min		0,75 l/min		1,5 l/min		
Traction and thrust force	0÷620 daN		0÷775 daN		0÷465 daN		
Operating ambient temperature	-40°C ÷ +55°C						
Thermal protection on motor winding	120°C						
Weight	8,6 kg						
Type of oil	FAAC HP OIL						
Protection class	IP 55						



Model	Use		
	Single leaf max length (m)	Nr. of leaves	Use frequency (cycles/hour)
400 CBC	2,20	1	70
400 SB	4,00	1	70
400 SBS	7,00	1	60
400 CBAC	2,20	1	70
400 CBACR	2,20	1	80
400 CBAC long	2,20	1	50
400 SB long	2,50	1	50



FAAC S.p.A. Via Benini, 1
40069 Zola Predosa - Bologna (Italy)
tel. +39 051 61724 · fax +39 051 758518
www.faacgroup.com

